

Wanco® Pivoting-Frame Radar-Speed Trailer



Owner's Manual

October 2015

Contents

- 1 Introduction 1**
 - 1.1 Read before using 1
 - 1.2 Principles of operation..... 1
 - 1.3 Applications..... 2
 - 1.3.1 Traffic calming 2
 - 1.3.2 Sign behavior..... 2
 - 1.3.3 Highways and large roadways 3
 - 1.3.4 Work zones 3
 - 1.4 Where to obtain service..... 3
- 2 Safety 5**
 - 2.1 Safety statements in this manual..... 5
 - 2.2 General safety..... 6
 - 2.3 Operating Safety 6
 - 2.3.1 Prior to use 6
 - 2.3.2 During operation 7
 - 2.4 Service safety 8
 - 2.5 Labels..... 8
- 3 Assembly 11**
 - 3.1 Drawbar 11
 - 3.2 Regulatory signs..... 12
 - 3.3 Speed limit numbers 12
- 4 Operation 13**
 - 4.1 Overview..... 13
 - 4.2 Before using..... 13
 - 4.3 Towing..... 13
 - 4.3.1 Before towing 13
 - 4.3.2 During towing 15
 - 4.3.3 After towing 16
 - 4.4 Deployment..... 16
 - 4.4.1 Locating the trailer..... 16
 - 4.4.2 Positioning the trailer 17
 - 4.4.3 Leveling the trailer 19
 - 4.4.4 Setting up the trailer 20
 - 4.4.5 Setting up the optional traffic data collector 22

4.5	Using the radar-speed trailer	23
4.5.1	Control panel	23
4.5.2	Operating modes	25
4.5.3	Speed display configuration options	29
4.6	Batteries	30
4.7	Auxiliary devices	30
4.7.1	Red-and-blue flashers	30
4.7.2	Strobe	30
4.7.3	Traffic data collector	30
4.7.4	Caution beacons	31
4.7.5	Scheduler	31
5	Troubleshooting	33
5.1	Safety	33
5.2	Status LEDs	33
5.2.1	Status display	33
5.2.2	Status indicator lights	35
5.2.3	Alarm codes	35
5.3	Rotary switches	35
5.4	Radar	36
5.5	Power system	37
5.5.1	Overview	37
5.5.2	Solar charging	37
5.5.3	Batteries	38
5.5.4	Power failure	38
6	Maintenance	39
6.1	Periodic maintenance	39
6.2	Display cabinet	40
6.2.1	Display cabinet door	40
6.2.2	Polycarbonate window	41
6.2.3	Photocells	41
6.2.4	Systems board	43
6.2.5	Selector board	48
6.2.6	Display modules	50
6.3	Power system	53
6.3.1	Solar panel	53
6.3.2	Batteries	53
6.4	Wiring	60
6.5	Replacement parts	60

List of Figures

Figure 1-1	Vehicle identification tag	4
Figure 2-1	Label locations	9
Figure 3-1	Wiring and harness	11
Figure 3-2	Drawbar installation	11
Figure 3-3	Regulatory-signs frame	12
Figure 4-1	Before towing	14
Figure 4-2	Tow-chain hook-up	15
Figure 4-3	Angular interference	17
Figure 4-4	Positioning the trailer	18
Figure 4-5	Sight-tube	18
Figure 4-6	Leveling the trailer	19
Figure 4-7	Pivot bracket and slide bar	21
Figure 4-8	Rotary switches on control panel	21
Figure 4-9	Traffic data collector	22
Figure 4-10	Traffic data collector orientation	22
Figure 4-11	Control panel	23
Figure 4-12	Speed display behavior	25
Figure 5-1	Speed limit selector	34
Figure 5-2	Radar head	36
Figure 6-1	Display cabinet door	40
Figure 6-2	Photocell locations	42
Figure 6-3	Accessing the systems board	44
Figure 6-4	DIP switches on the systems board	45
Figure 6-5	Selector board	49
Figure 6-6	Rotate display module	51
Figure 6-7	Initialize button and status LEDs on the systems board	53
Figure 6-8	In-line fuse	59
Figure 6-9	Systems board wiring connections	61
Figure 6-10	Wiring diagram	62
Figure 6-11	Speed-display cabinet, exploded view	64
Figure 6-12	Trailer assembly, exploded view	66
Figure 6-13	Battery-box assembly, exploded view	68

List of Tables

Table 2-1	Label samples and descriptions	9
Table 4-1	Status conditions	24
Table 4-2	Operating modes summary	26
Table 5-1	Operating information on 3-digit LED status display	33
Table 5-2	Variables shown on LED status display.....	34
Table 5-3	Status conditions	35
Table 5-4	Alarm codes	35
Table 6-1	DIP switch settings.....	45
Table 6-2	Battery charge requirements.....	56
Table 6-3	Speed-display cabinet parts list	65
Table 6-4	Trailer assembly parts list.....	67
Table 6-5	Battery box parts list.....	68

1 Introduction

1.1 Read before using

This is the owner's manual for the Wanco® Folding Radar-Speed Trailer.

For your safety and protection from injury, carefully read, understand, and observe all instructions in this manual. Always read all instructions before performing a procedure.

Keep this manual or a copy of it with the speed trailer. Additional and replacement manuals are available from the factory (see Section 1.4, "Where to obtain service," page 3).

If you have questions regarding this product, please contact Wanco Service or Sales using the information in Section 1.4.

1.2 Principles of operation

The speed trailer consists of the following essential components:

- Radar-speed sign cabinet with control box
- Regulatory speed limit sign with changeable digits
- Additional regulator signs provided by the user
- Solar charging system with batteries and battery box
- Trailer with folding frame for regulatory signs

The speed-sign cabinet comprises electronics, a full-matrix LED display, and a sign above the display that reads, "YOUR SPEED." A clear, polycarbonate-resin, thermoplastic window protects the display from the elements.

A radar head inside the sign cabinet points in the same direction as the sign, and measures the speed of oncoming traffic. When a motorist exceeds the user-configured speed limit, the display flashes the vehicle's speed.

Controls for the speed sign are located in a weathertight enclosure. This control box houses electronics and a control panel for configuring the sign's behavior. The control box is latched with two keyed locks. When locked, it is essentially tamper-resistant.

The speed sign is powered by batteries, which are charged using a solar panel and automated charging system. (For an overview of the charging system, see Section 5.5, page 37).

1.3 Applications

1.3.1 Traffic calming

By far the most common application of Wanco radar-speed signs is for traffic calming in locations where motorists regularly travel at unsafe speeds over the posted speed limit. Because of its large size, the sign is typically used on highways and in roadwork zones.

Factors to consider when deploying a Wanco radar-speed sign include:

- Road characteristics, shoulder condition, grade, alignment, and sight distance
- The pace of traffic
- Roadside development and environment
- Parking practices and pedestrian activity
- Reported crash experience for the preceding 12-month period

The radar-speed sign may be used in conjunction with permanent speed limit signs, and may be used independent of permanent signs, but should not be considered a replacement for a permanent sign. The radar-speed sign is intended for temporary use.

1.3.2 Sign behavior

The U.S. Department of Transportation's *Manual on Uniform Traffic Control Devices* (MUTCD), which defines the standards for traffic control devices on all public streets and private roads open to public traffic, specifies that temporary traffic control "... should be designed on the assumption that drivers will only reduce their speeds if they clearly perceive a need to do so."*

Wanco radar-speed signs address this assumption by providing real-time response. While the sign remains blank prior to a vehicle's approach, drivers are suddenly and instantly presented with their speed, rendered in bright amber LEDs against a black contrasting background, as they near the sign.

Speeding drivers are presented with their speed as it quickly and continuously flashes on and off until they slow down. Studies have shown that motorists generally respond to this type of display by decreasing their speed.

Drivers traveling at excessive speeds may also be presented with an excessive speed message, which flashes quickly and continuously until they slow down. The full-matrix LED display on the Wanco radar-speed sign, which was designed specifically for this purpose, is capable of displaying both text and symbols. Its excessive speed messages can be text that reads "SLOW DOWN" or an unhappy face (☹) or another preprogrammed graphic symbol. Configuration options include the ability to show text, a symbol, or neither.

The graphic symbols are particularly useful when an English-language message is not practical. Additionally, some drivers, when confronted with a changeable speed display that reacts to their speed, will "challenge" the sign by speeding up. A symbol discourages this behavior by replacing the driver's speed with a graphic message.

*MUTCD, December 2009 ed., Sect. 6B.01, ¶107 2.A.

1.3.3 Highways and large roadways

DOTs and other government agencies often deploy radar-speed signs on highways and other large roadways where speeding is a problem. When used in conjunction with the regulatory speed limit sign that is also part of the speed trailer, drivers receive immediate confirmation of their actual speed in comparison to the legal speed limit.

Where law enforcement agencies cannot continuously monitor speeds in any one location, a radar-speed sign can supplement speed limit enforcement, alerting drivers about their driving behavior.

Radar-speed signs are usually positioned on the shoulder where speed limits change, speeding is a problem, or excessive speeds may cause a particular hazard.

1.3.4 Work zones

DOTs and contractors use radar-speed signs for warning drivers to slow down when approaching a work zone. Road work creates a safety hazard for pedestrians, drivers, and workers on the road. Workers are particularly vulnerable to oncoming traffic.

The MUTCD specifically mentions the danger for workers, explaining that road work presents changes in road conditions “that are unexpected by the road user. This creates an even higher degree of vulnerability for workers on or near the roadway.” The MUTCD also states, “. . . devices that get the road user’s attention and provide positive direction are of particular importance.”*

Radar-speed signs are usually positioned on the shoulder well in advance of the work zone, warning of a significantly reduced speed limit. When used in combination with “ROAD WORK AHEAD” signs, the speed signs can be particularly effective for slowing drivers.

1.4 Where to obtain service

Before calling for service, please have the unit’s model number and VIN ready. This information is displayed on the vehicle identification tag (see Figure 1-1).

Contact our service department using the following information:

Wanco Inc.
 5870 Tennyson Street
 Arvada, Colorado 80003 USA

 303-427-5700
 fax 303-427-5725

 www.wanco.com
 info@wanco.com

*MUTCD, December 2009 ed., Sect. 6D.03, ¶1 & 2.

Figure 1-1. Vehicle identification tag

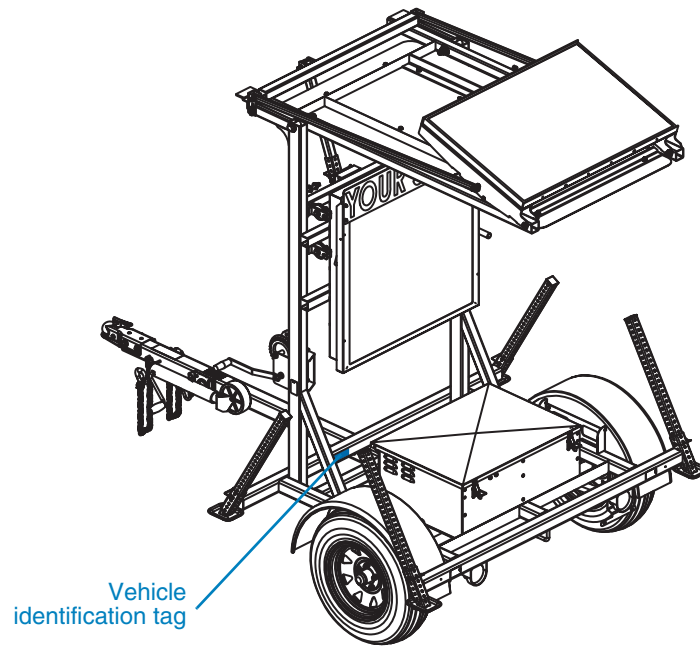

2 Safety

2.1 Safety statements in this manual

This manual contains the following types of callouts, which must be followed to reduce the possibility of personal injury, damage to the equipment, or improper service. Each alert has a specific meaning, as described below:

 The safety alert symbol alerts you to potential personal injury hazards. Obey all safety messages that follow this symbol to avoid possible injury or death.

DANGER

Indicates an imminently hazardous situation which, if not avoided, **WILL** result in death or serious injury.

WARNING

Indicates an imminently hazardous situation which, if not avoided, **COULD** result in death or serious injury.

CAUTION

Indicates a potentially hazardous situation which, if not avoided, could result in minor or moderate injury.

CAUTION

Used without the safety alert symbol, indicates a potentially hazardous situation which, if not avoided, could result in property damage.

IMPORTANT!

Indicates information that is of particular importance when transporting, operating, or servicing the equipment.

2.2

General safety



⚠ WARNING

Improper use of equipment could cause serious injury or death.

Prior to using this product, carefully read, understand, and observe all instructions in this manual.



⚠ CAUTION

Crush hazard.

When operating or working on the speed trailer, keep hands and body parts clear of pinch points.

2.3

Operating Safety

2.3.1

Prior to use

- To reduce the risk of personal injury, ensure the surrounding area is in good order and free of debris.
- To reduce the risk of shifting, rolling, or overturning, locate the speed trailer on a firm, level surface.



⚠ CAUTION

Falling equipment could result in damage and injury.

Before raising regulatory signs, stabilize and level the trailer.

- Always stabilize and level the trailer before raising the sign frame.
- Ensure the speed trailer is in good operating condition. Never use any equipment that is damaged or in need of repair.

2.3.2

During operation

 **WARNING**

Improper sign display could cause a traffic accident resulting in severe injury or death.

Visually inspect display to ensure proper operation.

 **CAUTION**

High winds can topple trailer, resulting in damage and injury.

Do not deploy trailer in winds over 60 miles per hour (97 kilometers per hour).

- Always visually inspect the electronic display to ensure it is operating as expected.
- Always replace display modules that are not functioning properly.
- The trailer is susceptible to wind blowing on the face of the display and regulatory sign. The trailer may tip and fall in a wind gust of 75 mph (120 km/h), or in sustained winds of 60 mph (97 km/h) or greater.
- Place sandbags on the trailer's stabilizer jacks to weigh it down and help prevent it from tipping.
- Do not move the trailer while the regulatory signs are raised.
- Do not allow water to accumulate around the base of the trailer.
- When the regulatory signs are raised, verify the snapper pin is engaged (inserted through both the slide-bar and pivot bracket) and locked in position.

2.4

Service safety



WARNING

Fire hazard.

When working with the speed trailer batteries, never allow positive wiring to short to ground.



CAUTION

Adverse weather conditions can result in equipment damage and injury.

Whenever possible, perform maintenance indoors.

- When working with batteries, never allow positive wiring to short to ground.
- Always take precautions to ensure the safety of service personnel. Whenever possible, perform maintenance indoors, out of weather and away from traffic.
- Never perform even routine service unless all electrical components are shut down. Ensure all speed trailer power circuits are shut off.
- If disconnecting speed trailer battery cables, always disconnect the positive (+) cable first.*
- If the ground under or around the trailer is damp or wet, move the trailer to a dry location and allow it to dry before servicing.
- Do not service the speed trailer if your clothing or skin is wet.
- Always be aware of traffic when performing roadside maintenance.
- Keep the speed trailer and all its components clean.

2.5

Labels

Labels provide instructions and information. They also warn of hazards. For convenience and safety, keep all labels in legible condition, replacing labels when damaged or missing. Replacement labels are available from the factory.

Label locations are indicated in Figure 2-1. Samples of labels and their descriptions are provided in Table 2-1.

**Removing the positive cable first is a requirement specifically for negative-ground systems.*

Figure 2-1. Label locations

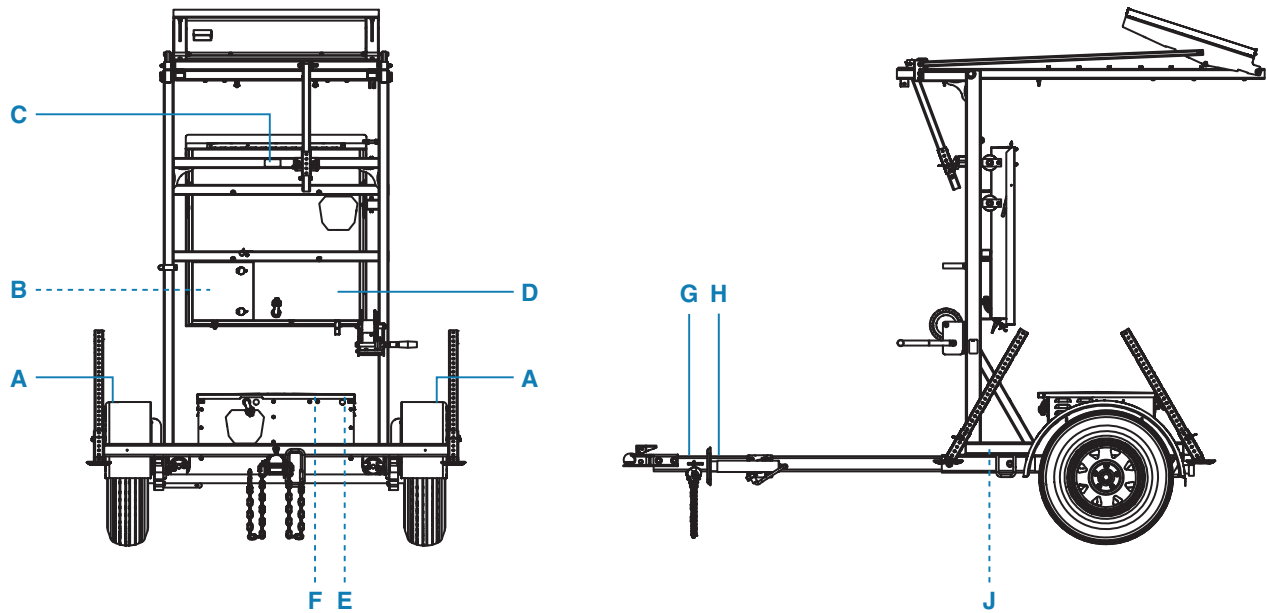

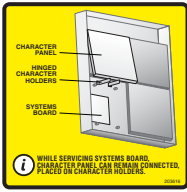

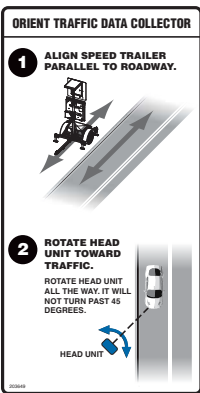

Table 2-1. Label samples and descriptions

Ref.*	Label (not to scale)	Description
A		Caution: not a step
B		Service instructions
C		Caution: insert locking pin
D		Orient data collector (if equipment is installed)

*Reference Figure 2-1 for label location.

Table 2-1. Label samples and descriptions *continued*

Ref.*	Label (not to scale)	Description
E		<p>Danger: battery maintenance Danger: battery voltage</p>
F		<p>Service record</p>
G		<p>Warning: towing connection</p>
H		<p>Caution: extend stabilizing jack</p>
J		<p>Vehicle identification tag</p>

*Reference Figure 2-1 for label location.

3 Assembly

3.1 Drawbar

Before using your Wanco Radar-Speed Trailer for the first time, it might be necessary to install the drawbar. The drawbar may be removed before shipment from the factory.

To install the drawbar, follow these steps:

1. The drawbar includes wiring for the trailer lights. Before installing the drawbar, ensure the wiring cable and harness are hanging out of the drawbar, as indicated in Figure 3-1.
2. Refer to Figure 3-2 and install the drawbar and wiring:
 - a. Locate the receiving sleeve, centered under the trailer frame.
 - b. Carefully insert the wiring and harness into the sleeve, followed by the drawbar.
 - c. Align the holes in the sleeve and drawbar.
 - d. Attach the drawbar to the trailer with two sets of bolts, washers, and nuts. Tighten the nuts fully.
 - e. Connect the wiring harness to the receptacle under the trailer frame. Before towing, ensure the trailer brake lights, taillights, and directional/turn indicators are functioning properly.

Figure 3-1. Wiring and harness

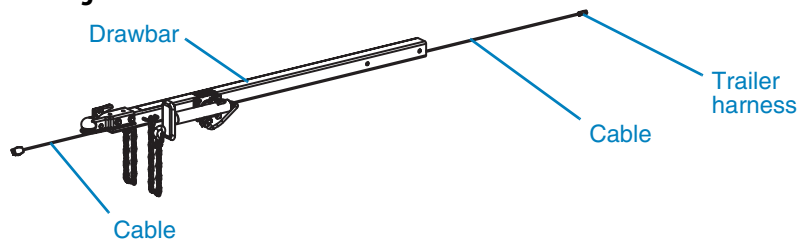
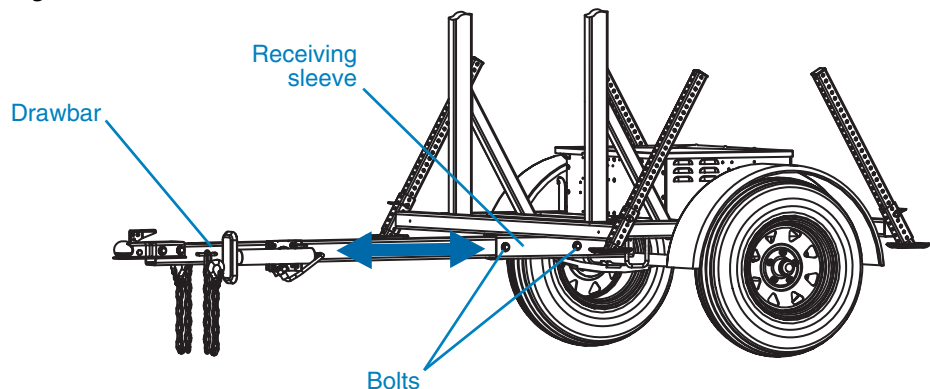

Figure 3-2. Drawbar installation



3.2 Regulatory signs

The Wanco Radar-Speed Trailer ships from the factory with a changeable speed limit sign, and may also ship with one or more regulatory signs. The signs may already be installed, or it may be necessary for you to install them.

The signs attach to the regulatory-signs frame (see Figure 3-3). The frame is folded down in the horizontal (or travel) position during shipment, and raised to the vertical (or deployed) position when the speed trailer is in use.

Before using the speed trailer, install the desired signs on the signs frame. Holes in the frame accommodate standard signs.

Figure 3-3. Regulatory-signs frame

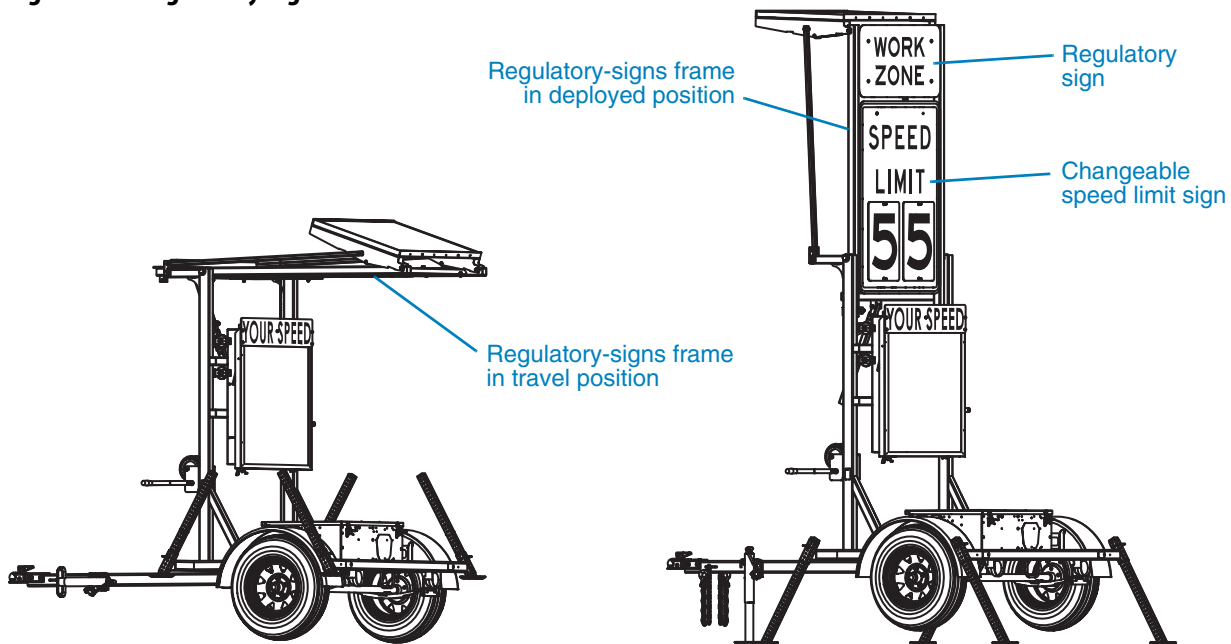

3.3 Speed limit numbers

The speed limit sign has detachable speed limit numbers. Before using the sign, install the proper digits on the regulatory sign to indicate the desired speed limit.

- Each digit attaches to the sign with two wingnuts.
- Additional and replacement sets of numbers are available from the factory (see Section 1.4, "Where to obtain service," page 3).

4 Operation

4.1 Overview

A typical deployment of the Wanco Radar-Speed Trailer includes the following steps:

1. Towing the trailer to its destination (Section 4.3)
2. Locating the trailer (Section 4.4.1, page 16)
3. Deploying the trailer, which includes:
 - a. Positioning (Section 4.4.2, page 17)
 - b. Leveling (Section 4.4.3, page 19)
 - c. Setup and configuration (Section 4.4.4, page 20)

4.2 Before using

Before using the Wanco Radar-Speed Trailer:

- Read and follow all safety instructions (see Section 2, page 5).
- Ensure batteries are fully charged.

4.3 Towing

4.3.1 Before towing

Before towing, refer to Figure 4-1 and prepare the speed trailer as follows:

1. Open the control box and set the operating mode to the OFF position.
2. Close and lock the control box.
3. Close and latch the battery box.
4. Lower the regulatory-signs frame:
 - a. Remove the snapper pin from the slide-bar pivot bracket.
 - b. Use the hand-operated winch to lower the frame to the horizontal (travel) position.
 - c. Reinsert the snapper pin through the pivot bracket and slide-bar, and lock it into place.

Figure 4-1. Before towing

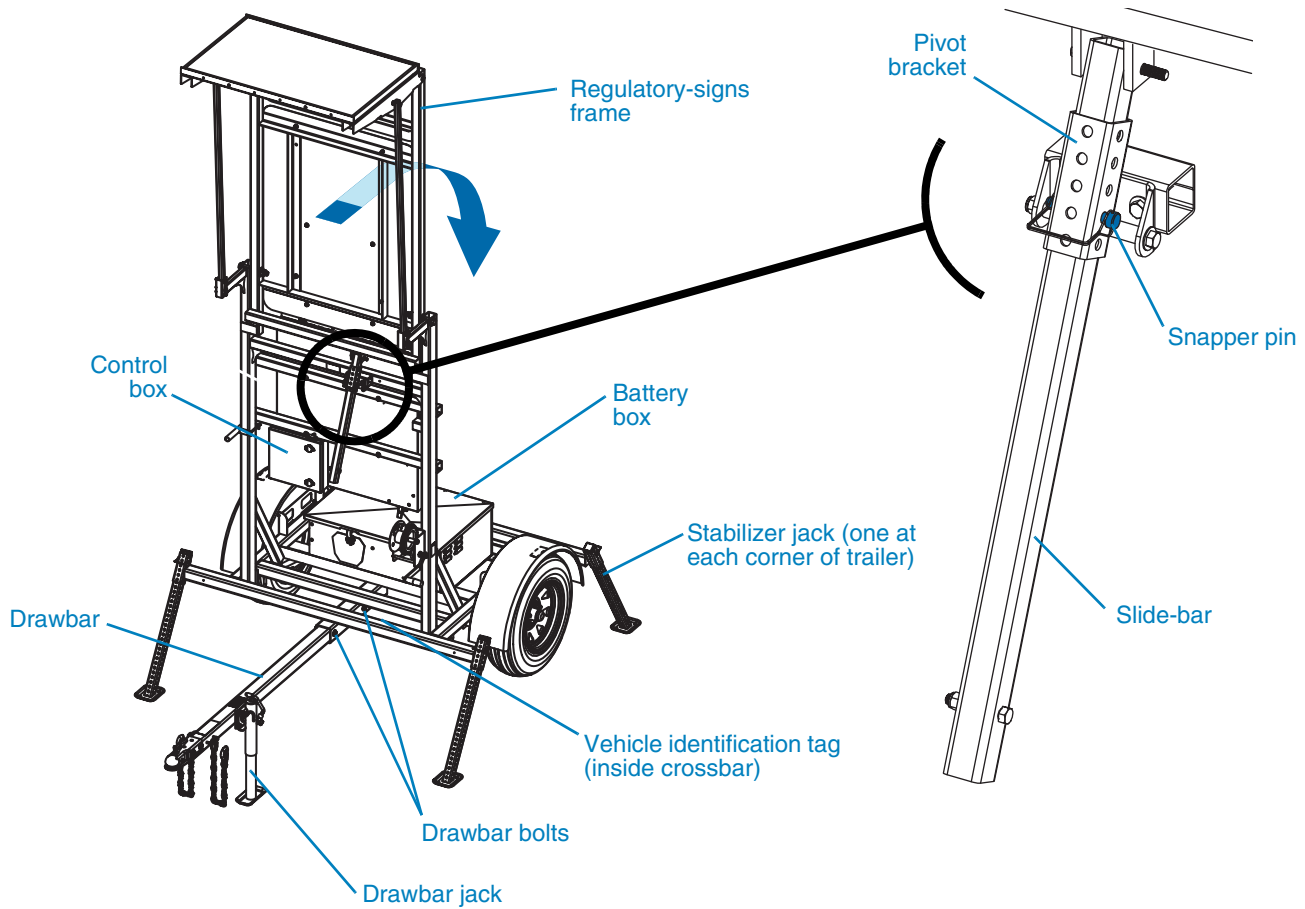

5. Check tires, wheels, and lights:
 - a. Check tires for wear. Replace worn tires.
 - b. Ensure tires are inflated to the proper pressure.
 - c. Verify all wheel lugs are in place and tightened. Do not tow the trailer if a wheel lug is missing.
6. Check the drawbar, tow hitch, and safety chains:
 - a. Ensure the tow hitch and coupling on the tow vehicle are rated for weight equal to or greater than the trailer's gross vehicle weight rating (GVWR). The GVWR is listed on the speed trailer vehicle identification tag.
 - b. Ensure the tow hitch on the tow vehicle and the drawbar hitch on the speed trailer are compatible.
 - c. Inspect the tow hitch and coupling for wear and damage. Replace or repair if necessary.
 - d. Ensure the trailer's detachable drawbar is attached securely to the trailer frame with two sets of bolts and nuts. The bolts should engage the drawbar and the nuts should be tight. (For drawbar installation instructions, see Section 3.1, page 11.)

- e. Lower the drawbar jack by pulling the jack locking pin and rotating the jack downward. Use the hand-crank to lower the jack foot until it touches the ground.
 - f. Raise and secure the two rear stabilizer jacks (at the rear corners of the trailer). To raise a jack, remove its snapper pin and slide the jack upward. Align the holes in the jack slide-bar with the holes in the slide bracket, then reinsert the snapper pin and lock it in place.
 - g. Use the drawbar jack to raise the front of the trailer and set the drawbar hitch on the tow vehicle hitch. Ensure the coupling is properly engaged and locked.
 - h. Raise, rotate, and lock the drawbar-mounted jack in the up position.
 - i. Raise and secure the two front stabilizer jacks (at the front corners of the trailer).
 - j. Verify approved safety chains are attached properly to both the trailer and tow vehicle, as illustrated in Figure 4-2. The chains should cross underneath the tow hitch.
7. Ensure the trailer brake lights, taillights, and directional/turn indicators are hooked up and functioning properly.
 8. Remove blocks or chocks from wheels, if present.
 9. Follow the towing requirements in Section 4.3.2.

Figure 4-2. Tow-chain hook-up

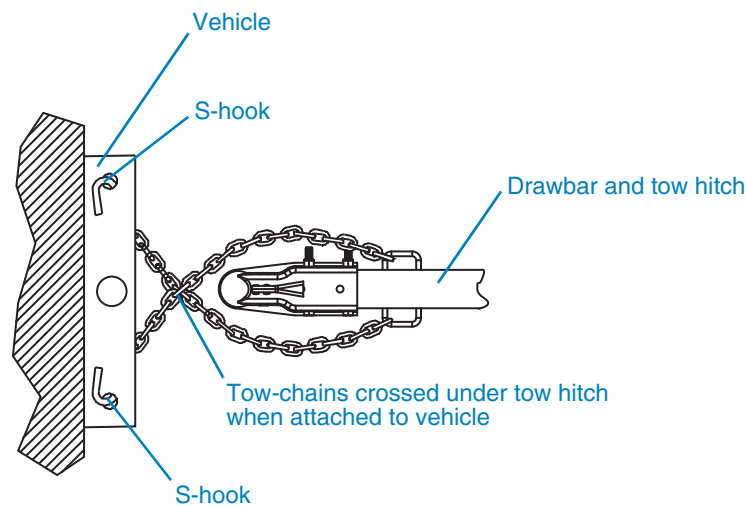

4.3.2

During towing

- Do not tow the trailer with any people, parts, supplies, or additional equipment attached to the trailer or loaded onto it.
- Do not tow additional trailers or other equipment in tandem with the speed trailer.
- The recommended maximum speed for highway towing is 65 mph (105 km/h). For off-road towing, the recommended maximum speed is 15 mph (25 km/h) or less, depending on terrain.
- Adhere to applicable transportation department regulations when towing the trailer.

4.3.3 After towing

After towing, unhook the tow chains from the tow vehicle, then use the drawbar-mounted jack to raise the drawbar and release the drawbar hitch from the tow vehicle. Pull the vehicle away from the speed trailer when ready.

4.4 Deployment

4.4.1 Locating the trailer



DANGER

Electric shock hazard.

Contact with overhead electrical power lines will cause serious injury or death.

Do not position speed trailer under power lines.

- When deployed, the speed trailer is more than 13 feet (4 meters) tall. When choosing a location, ensure the area above the trailer is clear of overhead wires and other obstructions.
- To reduce the risk of shifting, rolling, or overturning, locate the speed trailer on a firm, level surface.
- For the speed display's radar to function properly, do not locate the trailer at a sharp curve in the road. See Figure 4-3.
- An optimal location provides the radar with a line-of-sight from 500 to 1000 feet (155 to 310 meters), which allows ample time for the speed to appear on the display and for motorists to read and react to it. See Section 4.4.2.
- Fog, rain, snow, and blowing dust can reduce the detection distance from motorists to the speed display. Allow for possible weather conditions when selecting a location.
- For the speed trailer's solar charging system to function properly, locate the trailer where it will be exposed to full sunlight during daylight hours.
 - The solar panel is significantly affected by shadows. Avoid locating the trailer where the sun will be obstructed, such as under a tree or in the shadow of a building.
 - Ensure the solar panel is clean (see Section 6.3.1, page 53).

Figure 4-3. Angular interference

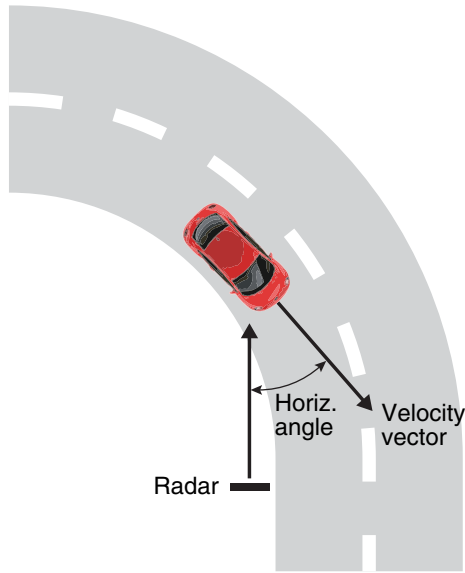

The cosine effect causes the speed display to indicate a speed that is lower than the vehicle’s actual speed. This occurs when the target vehicle’s path is at an angle to the radar, including conditions such as the vehicle traveling on a curve or hill. As the angle between the radar beam and the target vehicle increases, the displayed speed decreases (see table, below).

Ideally, an angle of zero degrees is preferable (i.e., the vehicle is traveling directly at the radar beam), because the displayed speed is the actual target vehicle speed. In all applications, however, the radar device is always at a slight angle to the target vehicle.

Effect on displayed speed of horizontal angle between radar and path of vehicle

Actual speed*	Horizontal angle							
	5°	10°	15°	20°	30°	45°	60°	90°
30	30	30	29	28	26	21	15	0
40	40	39	39	38	35	28	20	0
50	50	49	48	47	43	35	25	0
60	60	59	58	56	52	42	30	0
70	70	69	68	66	61	49	35	0
80	80	79	77	75	69	57	40	0
90	90	89	87	85	78	64	45	0
100	100	98	97	94	87	71	50	0
110	110	108	106	103	95	78	55	0
120	120	118	116	113	104	85	60	0

*Speed in any unit of measure.

4.4.2

Positioning the trailer

The angle of the speed display to the roadway is important for viewing by motorists. Proper positioning ensures motorists have the best chance of seeing and reacting to the display.

Optimal positioning provides the radar with a line-of-sight from 500 to 1000 feet (155 to 310 meters), which allows ample time for the speed to appear on the display and for motorists to read and react to it.

- Position the trailer so the rear of the trailer faces oncoming traffic.
- Angle the trailer slightly toward the roadway, as indicated in Figure 4-4.
 - ❑ Too great an angle creates a short viewing distance, and does not allow motorists enough time to see the speed display.
 - ❑ A slight angle provides a long viewing distance, and gives motorists plenty of time to see the speed display.
 - ❑ Look toward traffic through the sight-tube (Figure 4-5) and angle the sign display appropriately.
- For information about the limitations of positioning the trailer along a curve or hill in the road, see Section 4.4.1.

Figure 4-4. Positioning the trailer

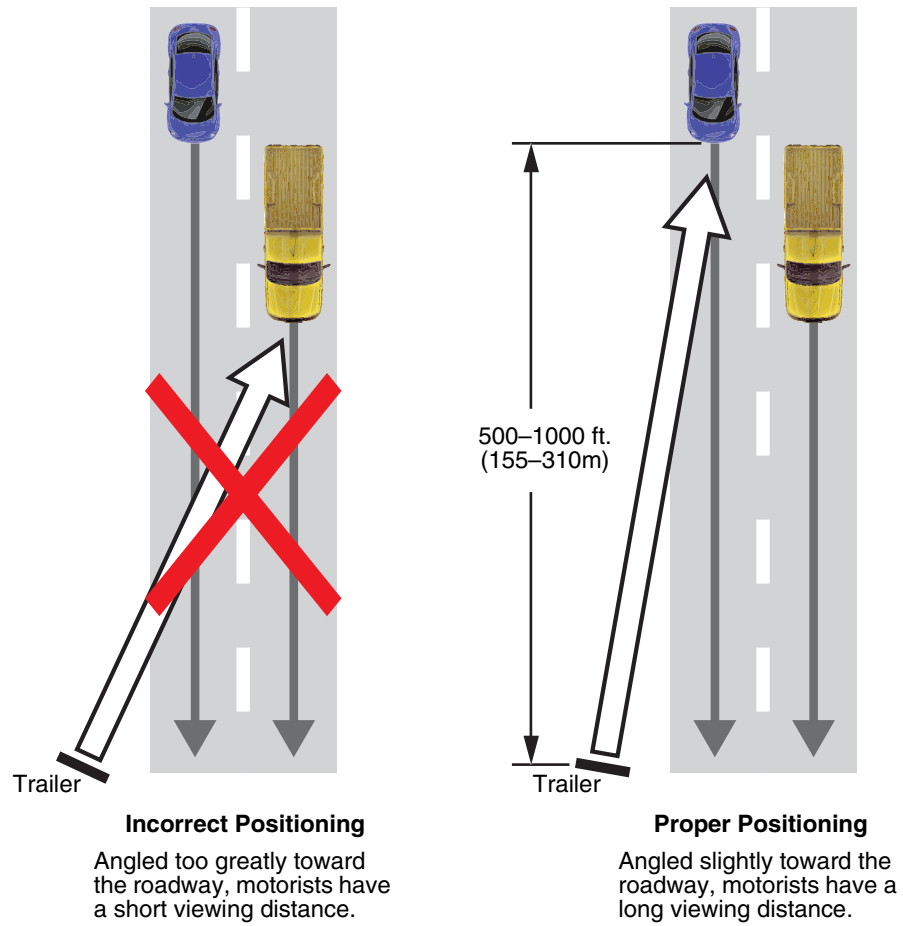
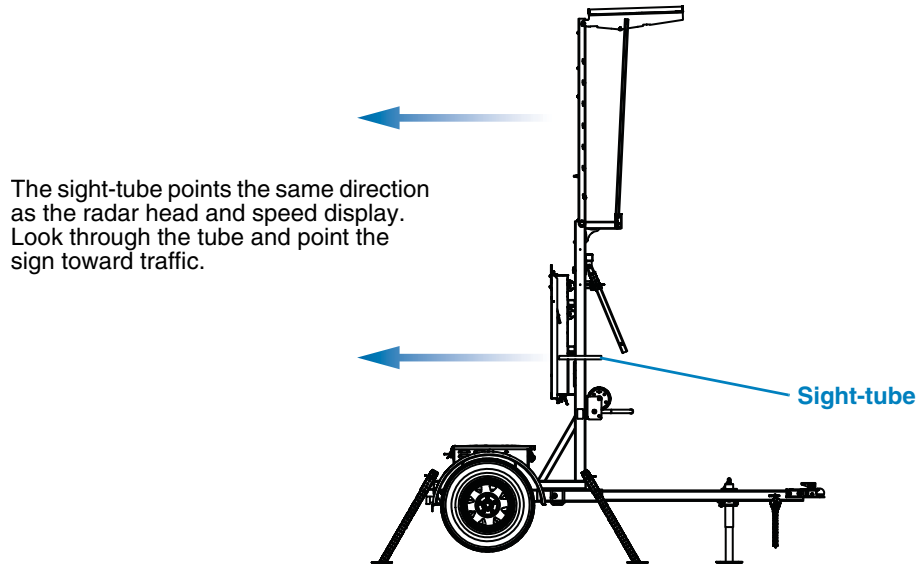

Figure 4-5. Sight-tube



4.4.3 Leveling the trailer

Prior to raising the regulatory-signs frame, the trailer must be level.



⚠ CAUTION

Falling equipment could result in damage and injury.

Before raising regulatory signs, stabilize and level the trailer.

When leveling the trailer, it may be necessary to make adjustments to account for variations in grade under the trailer. For example, the ground under the trailer may not be level. It is important for the trailer to be level before raising the regulatory-signs frame to the vertical position. If the trailer is not level, it could topple.

To level the trailer, refer to Figure 4-6 and follow these steps:

1. Lower the drawbar jack by pulling the jack locking pin and rotating the jack downward. Use the hand-crank to lower the jack foot until the trailer is level. At this stage, the trailer should be balanced on the tires and drawbar jack.
2. Use the drawbar jack to lower the drawbar toward the ground, until the trailer tilts forward slightly.
3. Lower the two rear stabilizer jacks (at the rear corners of the trailer) until they touch the ground. To lower a jack, remove its snapper pin and slide the jack downward. Align the holes in the jack slide-bar with the holes in the slide bracket, then reinsert the snapper pin and lock it in place.
4. Use the drawbar jack to raise the drawbar until the trailer is level. At this stage, the trailer should be balanced on the rear stabilizers and the drawbar jack, and the tires should be off the ground.
5. Lower the two front stabilizer jacks (at the front corners of the trailer) until they touch the ground, then lock them in place with their snapper pins. For each jack, align the holes in the jack slide-bar with the holes in the slide bracket, then reinsert the snapper pin and lock it in place.

Figure 4-6. Leveling the trailer

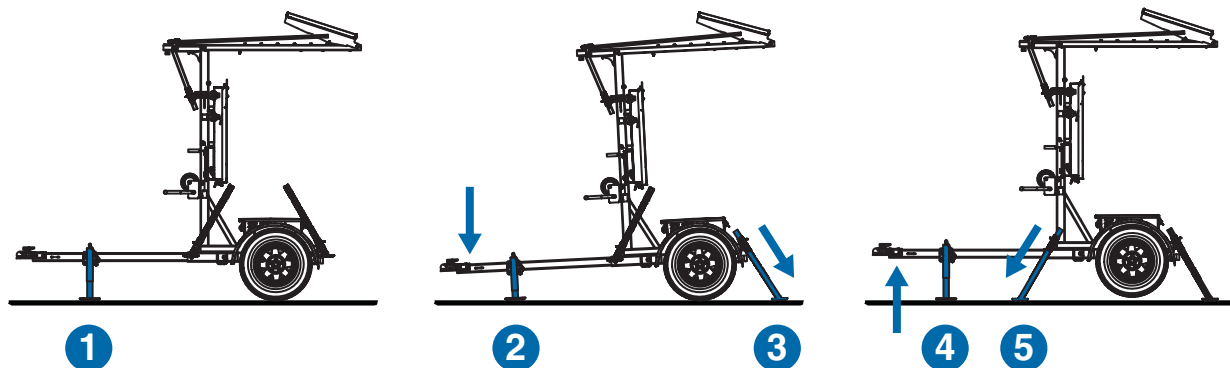

4.4.4 Setting up the trailer

After positioning and leveling the trailer (Sections 4.4.2 and 4.4.3), set up the trailer by following these steps:

1. Install the proper digits on the speed limit sign to indicate the desired speed limit (see Section 3.3, page 12).
2. Place at least one 50-pound sandbag on each of the four stabilizer jacks, to weigh down the trailer and help prevent it from tipping.



CAUTION

High winds can topple trailer, resulting in damage and injury.

Do not deploy trailer in winds over 60 miles per hour (97 kilometers per hour).

3. Raise the regulatory-signs frame (see Figure 4-7):
 - a. Remove the snapper pin from the slide-bar and pivot bracket.
 - b. Use the hand-operated winch to raise the frame to the vertical (deployed) position.
 - c. Reinsert the snapper pin through the pivot bracket and slide-bar, and lock it into place.
4. Set the speed limit and turn on the speed display:
 - a. Access the control box, located on the back of the speed-display cabinet (see Figure 4-7).
 - b. The control box cover is latched with two key-operated locking mechanisms. Each keyhole is protected by a plastic cover. Pull the tab on each cover to reveal the keyhole, then insert and rotate the key to release each lock.
 - c. Open the control box cover to access the control panel.
 - d. Set the desired speed limit using the speed limit selector (see Figure 4-8). For information about using the sign and selector switches, see Section 4.5, page 23.
5. Test the radar for proper operation:
 - a. At the control panel, set the operating mode to RADAR SETUP (see Figure 4-8).
 - b. As traffic approaches the sign, watch the LED display on the control panel, then the speed display. Speed should register for approaching traffic up to 1000 feet (315 meters) away.
 - If the speed display functions as expected, proceed to Step 6.
 - If the speed display functions but vehicle speeds appear to be wrong, it might be necessary to adjust the angle of the trailer in relation to the road. See Section 4.4.2, page 17.
 - If there is no traffic, use the tuning fork as described in Section 5.4, page 36.
 - If the radar appears to be malfunctioning, see Section 5.4, page 36.

- At the control panel, turn on the speed display by setting the operating mode to RUN.

IMPORTANT

In Radar Setup mode, the power drain is significant. To avoid a power failure, do not leave the trailer in the Radar Setup mode for extended periods.

- Close and lock the control box cover.

Figure 4-7. Pivot bracket and slide bar

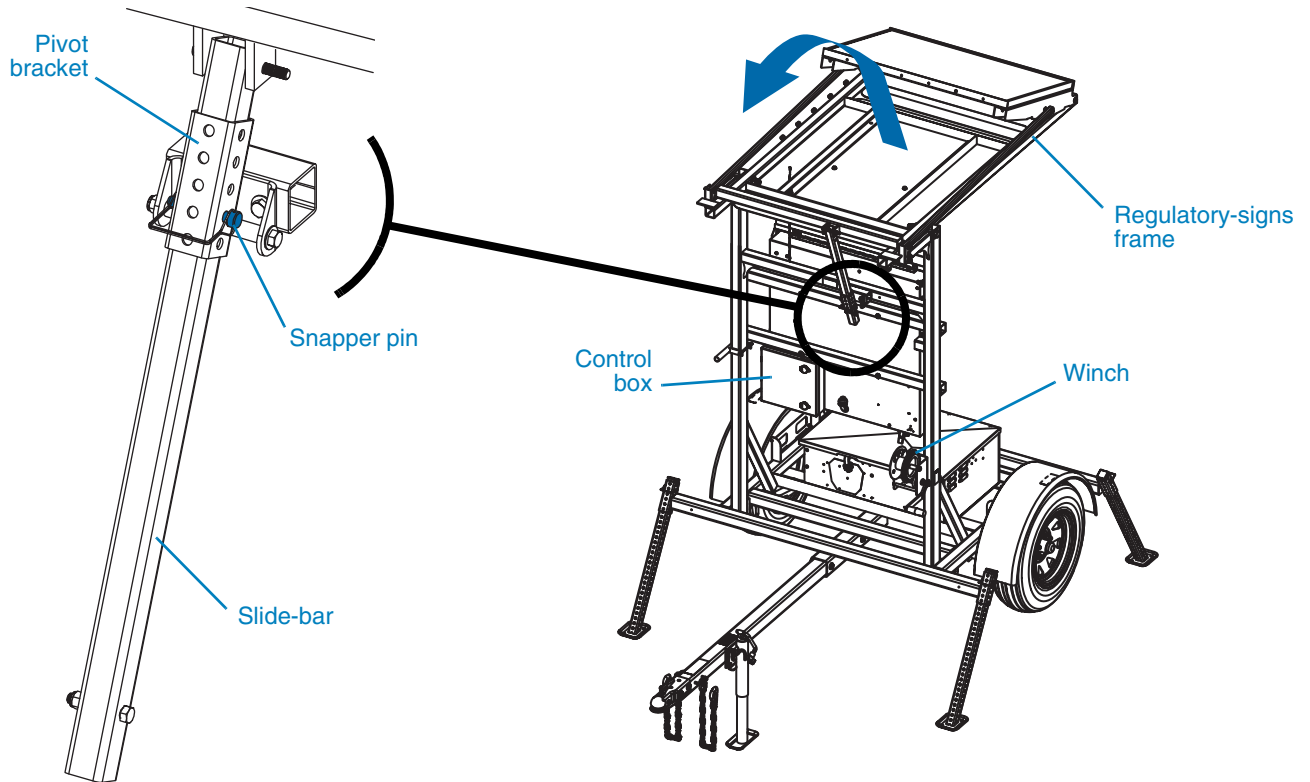
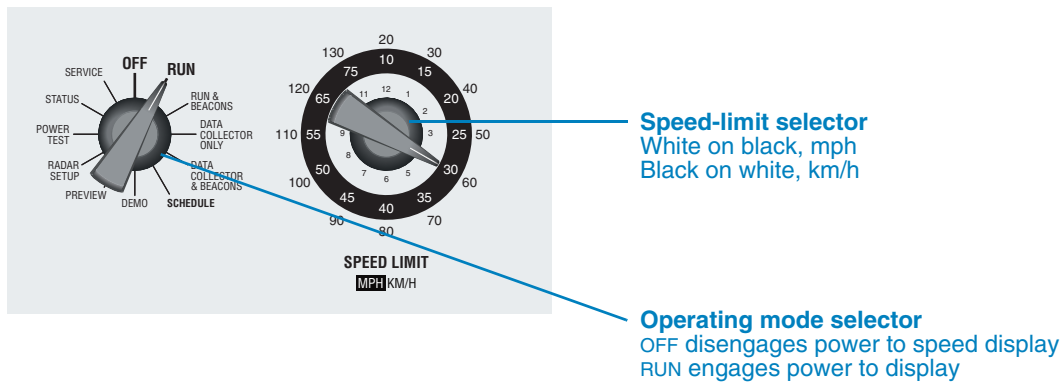

Figure 4-8. Rotary switches on control panel



4.4.5 Setting up the optional traffic data collector

If installed, the optional traffic data collector is attached to the bottom of the speed display cabinet.

To set up the data collector, refer to Figure 4-9 and follow these requirements:

- The data collector rotates from side to side, so that it can be correctly oriented. Press on the left or right side of its front surface until it points toward traffic at a 45-degree angle (see Figure 4-10). For the data collector to function properly, this angle must be as precise as possible.
- A tension bolt keeps the data collector from moving after proper positioning. If the data collector does not rotate, loosen the bolt slightly, using the provided hex key (the bolt has a special hexagonal socket).

Power to the traffic data collector is off when the operating mode is in the OFF position; otherwise, the data collector is on and logging traffic.

Figure 4-9. Traffic data collector

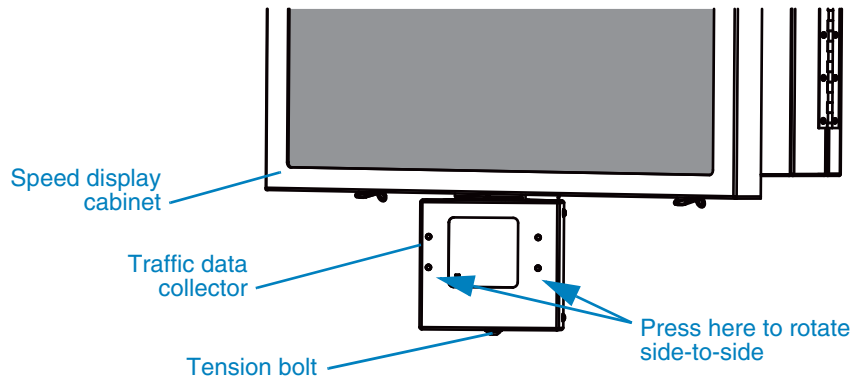
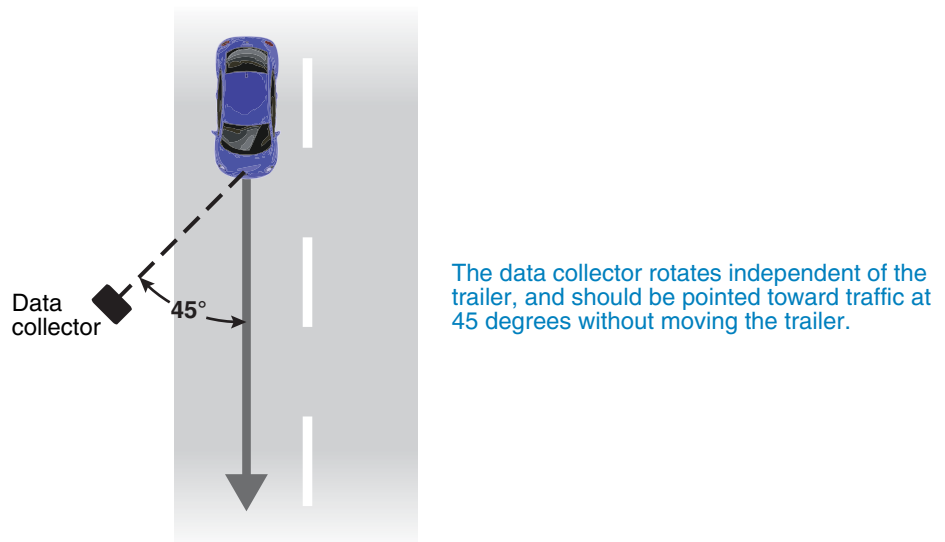

Figure 4-10. Traffic data collector orientation



4.5

Using the radar-speed trailer

4.5.1

Control panel

The speed trailer control panel is located behind a locking cover on back of the speed-display cabinet. The cover is latched with two key-operated locking mechanisms. Each keyhole is protected by a plastic cover. To open the control-box cover, pull the tabs on both plastic keyhole covers to reveal the keyholes, then insert and rotate the key to release both locks.

The control panel (illustrated in Figure 4-11) includes:

- A 3-digit LED status display that provides a variety of operating information
- Green, yellow, and red LEDs that indicate operating status
- A button that activates the LED display and colored LEDs after they have “timed out”
- Rotary switches for selecting the operating mode and speed limit
- A serial port (optional) for downloading data from the optional Wanco Traffic Data Collector

After using the control panel, ensure the control panel cover is closed and locked.

Status LEDs

During operation, status LEDs on the control panel indicate the speed trailer’s operating condition (see Table 4-1).

- To save power, the LEDs will “time out.” If all LEDs are off, press the ACTIVATE button.
- For alarm codes and troubleshooting, see Section 5, page 33.

Figure 4-11. Control panel

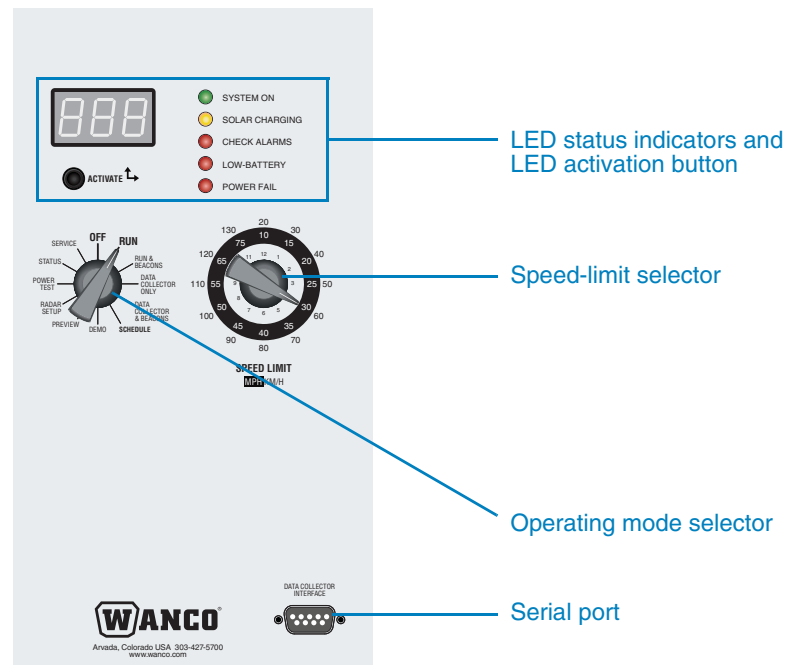

Table 4-1. Status conditions

Indicator	Condition	Status
3-digit LED status display	Speed or alarm code	While the system is functioning properly, typically indicates vehicle speed; in diagnostics mode, indicates alarm codes or system variables
SYSTEM ON	On	Radar and speed display are powered on and ready
SOLAR CHARGING	On	Solar charging system actively charging batteries
	Off	Solar charging system not charging batteries
	Blinking	Battery charging complete
CHECK ALARMS	On	System requires attention (see Section 5.2.3, page 35)
LOW BATTERY	On	Batteries require charging immediately
POWER FAIL	On	Battery charge fell below minimum charge voltage, system automatically shut down

Selector switches

The control panel includes two rotary switches that control system behavior (see Figure 4-11):

- The left rotary switch selects the operating mode.
- The right rotary switch sets the speed limit.
- The speed limit applies only when the left rotary switch is set to a normal operating mode.

Mode selector

The operating mode selector allows the speed sign to be switched off or set for normal operation, diagnostics, or servicing. When set to the RUN position, this selector works together with the speed limit selector.

Operating modes are described in Section 4.5.2.

Speed limit selector

The speed limit selector sets the speed limit during normal operation, and performs additional functions in various operating modes.

During normal operation, this selector should be set for the desired speed limit. Choose from 10 to 75 miles per hour in 5 mph increments, or from 20 to 130 kilometers per hour in 10 km/h increments. The choice of units is made using DIP switches on the systems board (see Section 6.2.4, page 43).

The selection made with the speed limit selector determines speed display behavior, as illustrated in Figure 4-12.

Serial port

The serial port is used for connecting a laptop computer to the speed trailer, for downloading data from the optional Wanco Traffic Data Collector (see Section 4.7.3, page 30).

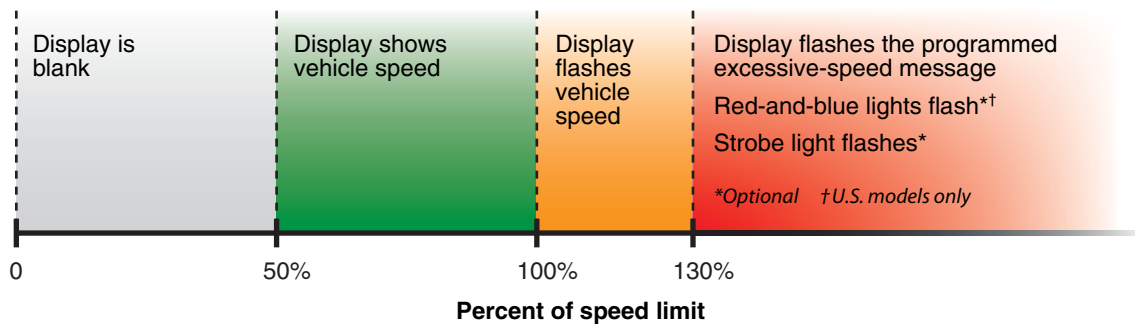
Figure 4-12. Speed display behavior

4.5.2

Operating modes

Operating modes are summarized in Table 4-2, page 26. See below for more details.

All modes

The charging system is active in all operating modes, even in the Off mode. While the solar panel is exposed to sunlight, it provides a charge to the batteries. For more information, see Section 5.5, "Power system," page 37.

The optional Wanco Traffic Data Collector, if installed, is on in all operating modes except the Off mode. For information, see Section 4.7.3, page 30.

The status LEDs on the control panel are active in all operating modes, and the appropriate LEDs light to indicate a specific condition (an active alarm, low battery voltage, etc.). If all LEDs are off, then they have "timed out" to conserve power. Press the **ACTIVATE** button to see the status LEDs. For details about status conditions indicated by the LEDs, see Section 5.2, page 33.

Off mode

When the speed trailer is not in use, it should be in the Off mode.

In the Off mode, the speed display is off and remains blank, the radar and all auxiliary devices except the data collector are off.

On the control panel, the 3-digit LED status display and status LEDs are off. When the **ACTIVATE** button is pressed, the status display shows "OFF" and the appropriate status LEDs are lit.

Table 4-2. Operating modes summary**Normal operation modes**

Mode	Radar	Charging system	Speed display	Flashers*	Caution beacons	Data collector	3-digit LED status display
Off	Off	Active	Off	Off	Off	Off	"OFF"
Run	On	Active	Vehicle speed and excessive-speed messages	On	Off	On	User-selected speed limit
Run & Beacons	On	Active	Vehicle speed and excessive-speed messages	On	On	On	User-selected speed limit with dots (e.g., "5.0")
Data Collector Only	Off	Active	Off	Off	Off	On	"CLA"
Data Collector & Beacons	Off	Active	Off	Off	On	On	"C.L.A."
Schedule	†	Active	Vehicle speed and excessive-speed messages based on programmed schedule†	On	†	†	"Sch"

Demonstration modes

Mode	Radar	Charging system	Speed display	Flashers*	Caution beacons	Data collector	3-digit LED status display
Demo	Off	Active	Cycles through 1-, 2-, and 3-digit speeds, excessive-speed messages, then repeats	On	Off	On	"[d]"
Preview	Off	Active	Cycles through available excessive-speed messages	Off	Off	On	"[P]"

Testing and servicing modes

Mode	Radar	Charging system	Speed display	Flashers*	Caution beacons	Data collector	3-digit LED status display
Radar Setup	On	Active	Vehicle speed, independent of speed limit setting	Off	Off	On	Vehicle speed
Power Test	Off	Active	All LEDs lit at fixed brightness, independent of input from photocells	On	On	On	System (AC or battery) voltage
Status	On	Active	Cycles through system status variables	Off	Off	On	System status information
Service	Off	Active	First letters of the alphabet	Off	Off	On	"[S]"

*When flashers are on, they activate (flash) during excessive speed conditions; otherwise, they are not lit.

†Timer controlled.

Run mode

The Run mode is the normal operating mode.

In the Run mode, the speed trailer and all installed auxiliary devices are on, and should function as expected. The speed display is fully functional, and behaves as illustrated in Figure 4-12, page 25, based on the position of the speed limit selector on the control panel.

DIP switches determine the unit of measure for the displayed speed (mph or km/h) and the displayed excessive-speed message. These settings can be changed by accessing the systems board (see Section 6.2.4, page 43). For more information about excessive-speed messages, see “Sign behavior” on page 2 and “Preview mode” on page 28.

On the control panel, the 3-digit LED status display shows the user-selected speed limit. The SYSTEM ON LED is lit, and the other status LEDs are lit if applicable.

Run & Beacons mode

The Run & Beacons mode has all the system functionality and behavior of the Run mode, but also activates optional caution beacons if they are installed. The beacons flash when activated by the approach of an oncoming vehicle.

On the control panel, the 3-digit LED status display shows the user-selected speed limit with three dots (such as “.5.0.”). The SYSTEM ON LED is lit, and the other status LEDs are lit if applicable.

Data Collector Only mode

The Wanco Traffic Data Collector is an optional, auxiliary device that can be integrally installed on the radar-speed trailer. Your trailer may or may not include this device. For more information, see Section 4.7.3, page 30.

In the Data Collector Only mode, the speed display is off and remains blank, the radar and all auxiliary devices except the data collector are off.

On the control panel, the 3-digit LED status display shows “CLA” or, if communication with the data collector fails, “Err”. The SYSTEM ON LED is lit, and the other status LEDs are lit if applicable.

Data Collector & Beacons mode

The Data Collector & Beacons mode has all the system functionality and behavior of the Data Collector Only mode, but also activates optional caution beacons if they are installed. The beacons flash when activated by the approach of an oncoming vehicle.

On the control panel, the 3-digit LED status display shows “C.L.A.” (with three dots) or, if communication with the data collector fails, “E.r.r.” The SYSTEM ON LED is lit, and the other status LEDs are lit if applicable.

Schedule mode

The Schedule mode uses an optional, auxiliary device that can be integrally installed on the radar-speed trailer. Your trailer may or may not include this device. For more information, see Section 4.7.5, page 31.

In the Schedule mode, the run mode and speed limit are controlled by the optional scheduling software; the speed limit selector has no effect. The speed display, radar, and all auxiliary devices including the data collector are controlled by the software.

On the control panel, the 3-digit LED status display shows "Sch". The SYSTEM ON LED is lit, and the other status LEDs are lit if applicable.

Demo mode

The Demo mode demonstrates the most common functions of the speed trailer, and can be used for verifying these functions are working properly.

In the Demo mode, the radar and auxiliary devices are off, except the optional flashers, strobe, and data collector. The speed display is on and cycles through preprogrammed sample speeds (showing 1-, 2-, and then 3-digit speeds), followed by excessive-speed messages. When the excessive speed messages appear, the red-and-blue flashers and strobe light flash, if installed. This cycle repeats continuously while in Demo mode.

On the control panel, the 3-digit LED status display shows "[d]". The SYSTEM ON LED is lit, and the other status LEDs are lit if applicable.

Preview mode

The Preview mode is used for viewing available excessive-speed messages and other test patterns, one at a time, regardless of the message that has been configured with DIP switches on the systems board (Section 6.2.4, page 43).

In the Preview mode, the radar is on, but all auxiliary devices except the data collector are off. The speed display is on and shows one excessive-speed message, which can be changed by rotating the speed limit selector. When the speed limit selector is in the "0" position, the display is blank.

On the control panel, the 3-digit LED status display shows "[P]". The SYSTEM ON LED is lit, and the other status LEDs are lit if applicable.

Radar Setup mode

The Radar Setup mode is used for verifying proper operation of the speed-trailer radar.

In the Radar Setup mode, the radar is on, but all auxiliary devices except the data collector are off. The speed display shows the speed of passing vehicles. Excessive-speed messages do not appear, regardless of the user-selected speed-limit setting.

On the control panel, the 3-digit LED status display shows the actual speed detected by the radar. The SYSTEM ON LED is lit, and the other status LEDs are lit if applicable.

IMPORTANT

In Radar Setup mode, the power drain is significant. To avoid a power failure, do not leave the trailer in the Radar Setup mode for extended periods.

Power Test mode

The Power Test mode is used for performing diagnostics on the power system.

In the Power Test mode, the radar is off, but all auxiliary devices are on. The speed-display has all LEDs on, lit at a fixed brightness independent of input from the photocells. If any LEDs are not lit, replace the appropriate display module (see Section 6.2.6, page 50).

On the control panel, the 3-digit LED status display shows the battery (system) voltage. If the voltage is lower than expected, see Section 5.5, page 37, for troubleshooting. The SYSTEM ON LED is lit, and the other status LEDs are lit if applicable.

Status mode

The Status mode is used for performing diagnostics on the electrical system and sensors. For information about status conditions, see Section 5.2, page 33.

In the Status mode, the radar is on, but all auxiliary devices except the data collector are off. The speed display cycles through five sets of system status variables. Additional system parameters can be shown by rotating the speed limit selector.

On the control panel, the 3-digit LED status display shows a user-selected system status variable. The selection is made using the speed limit selector. The SYSTEM ON LED is lit, and the other status LEDs are lit if applicable.

Service mode

The Service mode is used for servicing the speed display modules. For more about servicing, see Section 6, page 39.

In the Service mode, the radar and all auxiliary devices except the data collector are off. The speed display shows the first eight letters of the alphabet—ABCD on the top row, and EFGH on the bottom row.

On the control panel, the 3-digit LED status display shows “[S]”. The SYSTEM ON LED is lit, and the other status LEDs are lit if applicable.

4.5.3

Speed display configuration options

The speed display shows vehicle speed in either miles per hour (mph) or kilometers per hour (km/h). Additionally, when a vehicle is traveling at an excessive speed, the display shows a preprogrammed message.

The units of measure and the excessive-speed messages are configured with DIP switches on the systems board, and can be changed if necessary.

- For more information about excessive-speed messages, see Section 1.3.2, page 2.
- For more information about the systems board and setting DIP switches, see Section 6.2.4, page 43.

4.6 Batteries

To ensure battery health, follow these requirements:

- Do not allow batteries to fully discharge.
- Ensure batteries are fully charged before using the speed trailer.
- Charge batteries after each period of use, before putting the speed trailer into temporary or long-term storage.
- Power to the speed trailer is on at all times, and can only be stopped when the batteries are disconnected. Therefore, it is vital to set the operating mode to the OFF position when the trailer is not in use.
- For an overview of the speed trailer's power system, see Section 5.5, page 37.
- For battery charging information, see Section 6.3.2, page 53.

4.7 Auxiliary devices

4.7.1 Red-and-blue flashers

For applications where increased attention to the speed sign is desired, red-and-blue flashers are available as an option. When the speed display shows the excessive-speed message, these lights flash in an alternating pattern, like the lights on a police car, drawing the motorist's attention to the sign.

The flashers are located inside the display cabinet, at the bottom of the display.

4.7.2 Strobe

To simulate the flash of a photo-radar camera, a strobe light is available as an option. When the speed display shows the excessive-speed message, the strobe light flashes, as though the driver's photo has been taken.

The strobe is located inside the display cabinet, at the bottom of the display.

4.7.3 Traffic data collector

The Wanco Traffic Data Classifier System collects and analyzes traffic flow. The system includes a data collector and traffic analyzer software. The data collector is a non-intrusive device that uses side-firing radar to capture traffic volume by recording vehicle speed, direction, and length, along with the time and date. The data can be downloaded to a computer for analysis using software that is provided with the device. The data collector is installed on the bottom of the radar-speed display cabinet.

The traffic data collector is installed as an optional component, wired into the same power system as the speed display. Power to the data collector is controlled using the mode selector on the speed display control panel.

A serial port on the control panel is used for connecting a laptop computer to the speed sign for downloading data from the traffic data collector.

For setup information, see Section 4.4.5, page 22.

4.7.4 Caution beacons

Wanco caution beacons feature bright, amber LED lights that attract motorists' attention. Installed with a radar-speed display, single beacons flash on and off when an oncoming vehicle approaches, or at programmed times using the optional scheduler. Dual beacons alternate flashing (one is on while the other is off).

4.7.5 Scheduler

For applications that require operation based on a timetable, the optional scheduler provides programming capability. Using its software, you can program the speed display and other components so that the system runs automatically.

In addition to controlling operating modes and connected devices, the scheduler also allows for timed operation at specific times of day, on specific days of the week, and during specific times of year. For example, a sign in a work zone can be programmed to have caution beacons flashing only during work hours.

5 Troubleshooting

5.1 Safety

Before performing any troubleshooting or servicing on the speed trailer, observe all safety precautions in Section 2.4, page 8.

5.2 Status LEDs

During operation, status LEDs on the control panel indicate the speed trailer's operating condition.

- To save power, the LEDs will "time out." If all LEDs are off, press the **ACTIVATE** button.
- If no LEDs light after pressing the **ACTIVATE** button, check the power cable between the systems board (Section 6.2.4, page 43) and the selector board (Section 6.2.5, page 48).

5.2.1 Status display

The 3-digit LED status display shows a variety of operating information based on the operating mode. See Table 5-1.

In the Status mode, the status display on the control panel (as well as the speed display) shows various system variables based on the position of the speed limit selector. See Figure 5-1 and Table 5-2.

Table 5-1. Operating information on 3-digit LED status display

Operating mode	Shown on display
Off	"OFF"
Run	User-selected speed limit
Run & Beacons	User-selected speed limit with dots (e.g., "5.0.")
Data Collector Only	"CLA" (operating) or "Err" (communication failure)
Data Collector & Beacons	"C.L.A." (operating) or "E.r.r." (communication failure)
Demo	"[d]"
Preview	"[P]"
Radar Setup	Vehicle speed
Power Test	System voltage
Status	System status variable (see Table 5-2)
Service	"[S]"

Figure 5-1. Speed limit selector

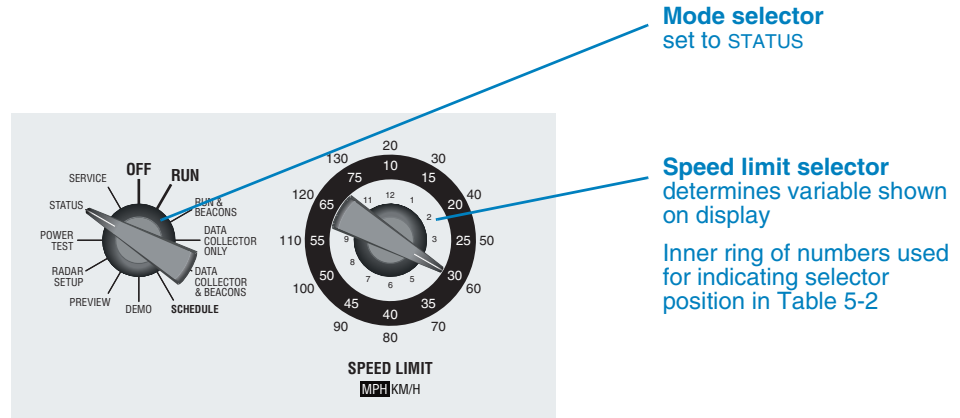

Table 5-2. Variables shown on LED status display

Selector position	Variable	Description	In-system value
1	v.DispBd	Display board version	varies
2	v.SysBd	Systems board version	varies
3	v.SelBd	Selector board version	varies
4	Pr	Rear photocell	0 to 100 (%), 3 to 90 typical
5	Pf	Front photocell	0 to 100 (%), 3 to 90 typical
6	Br	Display brightness	0 to 100 (%), 0 to 50 typical
7	Alarms	Alarm codes	see Section 5.2.3
8	Vsolar	Solar voltage	0 to 21 (VDC)
9	Vbtty	Battery voltage	12 to 13.75 (VDC)
10	Isolar	Solar current to batteries	0 to 5 (A)
11	Isys	System current	0 to 3.00 (A)
12	Ts	Display cabinet temperature	0 to 165 (°F) or -17.8 to 73.9 (°C)*

*Unit of measure based on speed units: if mph, temperature is Fahrenheit; if km/h, then Celsius.

5.2.2 Status indicator lights

The red, yellow, and green LEDs on the control panel indicate the status conditions described in Table 5-3.

5.2.3 Alarm codes

When the CHECK ALARMS indicator on the control panel is lit, alarm codes are available for viewing. Alarms are used during diagnostics, to identify components or systems that may be causing a problem.

To check alarms, set the operating mode to STATUS and rotate the speed limit selector to position 7. The 3-digit LED display on the control panel will show one of the alarm codes listed in Table 5-4.

Table 5-3. Status conditions

Indicator	Condition	Status	Troubleshooting instructions
SYSTEM ON	On	Radar and speed display are powered	—
SOLAR CHARGING	On	Solar charging system actively charging batteries	—
	Off	Solar charging system not charging batteries	see Section 5.5.2, page 37
	Blinking	Battery charging complete	—
CHECK ALARMS	On	System requires attention	see Section 5.2.3
LOW BATTERY	On	Batteries require charging immediately	see Section 5.5.3, page 38
POWER FAIL	On	Battery charge fell below minimum charge voltage, system automatically shut down	see Section 5.5.4, page 38

Table 5-4. Alarm codes

Alarm code*	Component or system	Status	Troubleshooting instructions
01	Display bd	One or more character display modules may have failed	see Section 6.2.6, page 50
02	A/D 12C	The analog/digital converter chip requires attention	contact the factory
04	Tc	Systems board temperature is too high	contact the factory
08	Solar	Solar charging system not functioning	see Section 5.5.2, page 37
10	Radar	Radar or radar wiring connections have failed	see Section 5.4, page 36
20	Ts comm	Temperature sensor communications failure	contact the factory
40	Ts bad	Display cabinet temperature too high	contact the factory
80	Ts critical	Display cabinet temperature critically high	contact the factory

*Alarm codes are hexadecimal values. Codes not listed above are combinations of two or more codes (e.g., code 21 = codes 01 and 20).

5.3 Rotary switches

If either rotary switch on the control panel appears to be malfunctioning (i.e., if the operating mode or speed limit does not change after rotating the corresponding switch), the problem may be that the switch is dirty or broken.

To clean a rotary switch, remove the selector board from the control panel (see Section 6.2.5, page 48) and clean the switch if it is dirty. If the problem persists, the switch may be broken. Contact the factory for a replacement selector board.

5.4 Radar

Test the radar for proper functioning using the tuning fork provided with the radar-speed trailer. (The tuning fork is located inside the control box when shipped from the factory).

IMPORTANT

Avoid striking the tuning fork too hard or its frequency will change, making the radar test invalid. A light tap on a hard surface is all that is necessary.

- The standard tuning fork shipped by the factory is calibrated for 55 mph. When tapped and held in front of the radar head, the sign should display 55 mph (86 km/h). An optional tuning fork is available from the factory that is calibrated to 33.2 mph (53 km/h).
- If the tuning fork appears to be damaged, or has dents or deep scratches, it may no longer vibrate at the proper frequency. A damaged tuning fork should be replaced by contacting the factory (see Section 1.4, "Where to obtain service," page 3).

To test the radar:

1. Lightly tap the tuning fork on a hard surface, such as a stabilizer jack. (To avoid damaging the finish on the trailer, do not tap the tuning fork on the trailer frame.)
2. Hold the tuning fork approximately 6 to 10 inches (15 to 25 cm) in front of the radar head (see Figure 5-2), and view the speed on the display. It should show 55 (mph) or 86 (km/h).
 - When holding the tuning fork in front of the radar head, do not move it side to side or wave it in front of the radar head.
 - If the display does not read 55 or 86, the radar or the tuning fork may need to be replaced.
 - If the radar does not respond, check wiring connections at the systems board (see Section 6.2.4, page 43).

Figure 5-2. Radar head

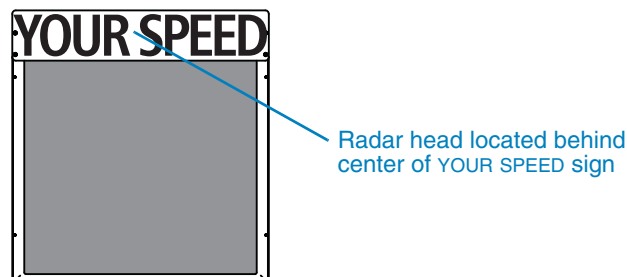

5.5 Power system

5.5.1 Overview

The speed trailer is powered by batteries, which are charged using a solar panel and automated charging system. The default system uses 6-volt batteries wired in series and parallel for a 12-volt power supply. Other battery configurations are also available.

The charging system runs continuously, keeping the batteries charged. The system automatically detects when the batteries are fully charged and will not overcharge them.

The low-voltage-disconnect circuit detects when the battery charge falls below 11.2 volts DC, and shuts down the speed display. If the optional traffic data collector is installed, the low-voltage-disconnect circuit shuts down power to the data collector when the battery charge falls below 10.7 volts DC.

5.5.2 Solar charging

For the solar charging system to function properly, the solar panel must be exposed to full sunlight during daylight hours. The solar panel must be kept clean and unobstructed.

When the solar charging system is functioning properly in a locale with bright, sunny days, the batteries should power the speed display indefinitely. If the battery charge drops, one or more of the following conditions may be true:

- The solar panel is not receiving enough sunlight to charge the batteries fully. Ensure the trailer is located where the solar panel is exposed to full sunlight.
- One or more batteries need replacing. See Section 5.5.3.
- The solar panel is dirty. When necessary, clean the solar panel with a soft cloth or sponge and a cleaning solution of mild detergent and warm water.
- The solar panel is broken. Check the panel for damage. If there is no visible damage, check the diodes inside the junction box on the back of the solar panel.

5.5.3

Batteries

When the LOW BATTERY indicator on the control panel is lit, complete power failure is imminent and the batteries should be charged immediately. The batteries are fully charged when their voltage is 12.65 VDC.

The cause of a low battery warning can include:

- The solar charging system is not charging the batteries. See Section 5.5.2.
- A cable connection is loose. Check battery terminals.
- Batteries have not been charging for a long enough time. Ensure charging is taking place, then wait and check the status LED again.
- Batteries need more water. See “Watering flooded batteries” on page 58.
- One or more batteries need to be replaced. Batteries that are more than three years old should be replaced. Check the batteries.

For battery charging instructions, see Section 6.3.2, page 53.

5.5.4

Power failure

When the POWER FAIL indicator on the control panel is lit, a complete power failure has occurred and the speed trailer has stopped functioning. A power failure can occur for any of the reasons described above.

6 Maintenance

6.1 Periodic maintenance

When performing any maintenance on the system, follow the safety requirements in Section 2.4, page 8.

Repair or replace worn and damaged components immediately. Never use any equipment that is damaged or in need of repair.



CAUTION

During maintenance, adverse weather conditions can cause equipment damage and injury.

Whenever possible, perform maintenance indoors.

The following items should be checked regularly:

- Check battery fluid levels
- Inspect winch cable for wear and damage
- Inspect display cabinet window for damage
- Inspect gasket, between the display cabinet door (window) and cabinet, for wear
- If status LEDs indicate a problem, see Section 5.2, page 33.
- All components in the battery box will operate more efficiently and have a longer lifespan if they are free of dirt and dust. Keep the interior of the battery box and components inside the battery box clean. Observe battery safety requirements when working on or around batteries (see “Safety” on page 54).

6.2 Display cabinet

6.2.1 Display cabinet door

The display cabinet protects the LED display modules and other electronics inside the cabinet. The door, which is hinged at the top and latched at the bottom, can be opened for various service needs.

- The door frame holds a clear, polycarbonate-resin thermoplastic window. During use, the window will become dirty and require cleaning (see Section 6.2.2).
- A gasket between the door frame and the display cabinet can become worn over time. The gasket is important for sealing the cabinet against the weather, and should be replaced if damaged.
- Ensure the cabinet door is closed and latched when the equipment is not being serviced.

To open the display cabinet door panel, refer to Figure 6-1 and follow these instructions:

1. Release the latches on the underside of the display cabinet. If a padlock is in place, remove the padlock.
2. The door is hinged at the top. To open the door, pull the bottom of the door away from the cabinet.
3. Lift the door as far as possible, then press upward on the center of each door support arm until it locks in place and holds the door open.

To close the display cabinet door, hold the door open with one hand and press downward on the center of each door support arm until it releases. Gently close the door, then latch both latches.

Figure 6-1. Display cabinet door

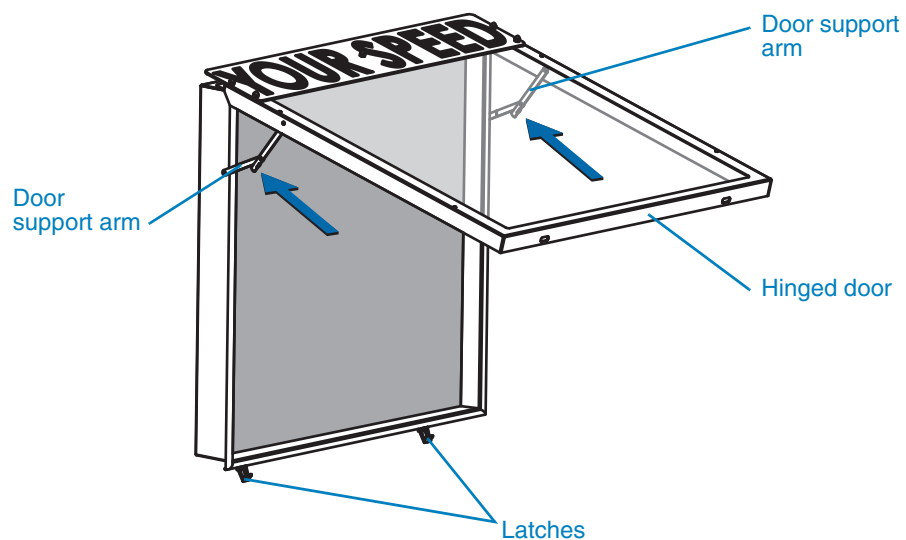

6.2.2 Polycarbonate window

The speed-display character panels (display modules) are protected by a clear, polycarbonate-resin, thermoplastic window, which occasionally needs cleaning.

To clean the window:

1. Follow the safety requirements in Section 2.4, page 8.
2. Open the display cabinet door as described in Section 6.2.1, page 40.
3. Follow these guidelines:
 - Use a cleaning solution of mild soap and warm water. If necessary, commercial cleaning solutions, such as Formula 409®, are acceptable. Do not use chemical or industrial cleaning solutions.
 - Use a sponge or soft cloth and clean the window gently, using care not to scratch the surface. Do not use a brush or squeegee.
 - To prevent spotting or streaking, dry surface with a soft cloth or moist sponge.

6.2.3 Photocells

The speed-display is equipped with two photocells, which are used for controlling the brightness of the speed display.

- If the display appears to be abnormally dim, one or both photocells may be blocked or defective.
- If the display appears to be abnormally bright, one or both photocells may have short-circuited or become damaged.

To check and replace the photocells:

1. Follow the safety requirements in Section 2.4, page 8.
2. Access the control panel (Section 4.5.1, page 23) and set the operating mode to STATUS. In the Status mode, the speed display cycles through several status conditions, including display brightness based on input from the photocells.
3. Locate the photocells on the display cabinet (see Figure 6-2). The front photocell is inside the cabinet, behind the clear door panel. To access this photocell, open the door (see Section 6.2.1).
4. If either the front or rear photocell appears to be dirty or otherwise obstructed, clear it or clean it. Use a soft, damp cloth to clean the photocell or photocell cover. For the front photocell, clean the window if necessary.
5. While watching the display, block all light from the photocells by holding a thick rag, work gloves, or any opaque object over both photocells.
 - Do not use your hands or a piece of paper to block the light.
 - As the display cycles through various status conditions, with light blocked from reaching the photocells, the PHOTO values should be at or near zero (indicating no light and full dimming of the display).

Figure 6-2. Photocell locations

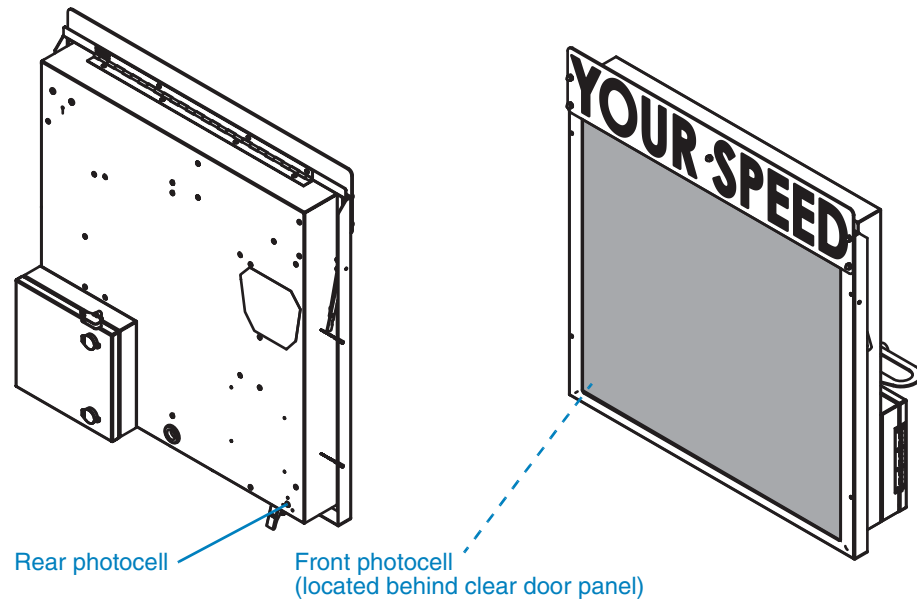

6. While watching the display, shine a flashlight at the front photocell, then at the rear photocell.
 - As the display cycles through various status conditions, with light shining directly into the front photocell, the top PHOTO value should be at or near 100 (indicating bright light and full brightness of the display).
 - With light shining directly into the rear photocell, the bottom PHOTO value should be at or near 100 (indicating bright light and full brightness of the display).
7. If, when performing the previous two steps, the PHOTO values do not indicate full dimming and full brightness, then one or both photocells may be damaged or defective. To replace the photocells:
 - a. At the control box, set the operating mode to OFF.
 - b. With the display cabinet door open, access the circuit board on which the photocells are mounted.
 - c. A locking tab on the front of the photocell wiring connector keeps the connector attached to the circuit board. Remove the connector from the board by pushing the locking tab toward the connector, then pulling the plug sideways, away from the board.
 - d. Remove the screws that hold the circuit board in place, then remove the board and set it aside.
 - e. Insert the replacement photocell circuit board into place, attach it with the screws, and connect the photocell wiring by installing the wiring connector to the board.
8. At the control box, set the operating mode to STATUS.

9. Repeat Steps 5 and 6.
 - If the photocell numbers on the display change as expected, the new photocells are correctly installed.
 - If the numbers do not change as expected, check the wiring connection at the photocell circuit board. If the connection is secure, check the other end of the wiring at the systems board (see Section 6.2.4).
 - If all wiring connections are secure and the photocells do not appear to be working correctly, contact the factory (see Section 1.4, “Where to obtain service,” page 3).
10. Close and latch the display cabinet door (see Section 6.2.1, page 40).

6.2.4

Systems board

The systems board includes wiring connections and switches that allow for additional configuration of the speed sign and its behavior. Although the factory establishes all the settings necessary for proper operation, based on customer specifications, it is sometimes necessary to access the systems board.

Accessing the systems board



⚠ CAUTION

Wind can cause the display cabinet door or display module to fall, resulting in equipment damage and injury.

Do not attempt to access the systems board in windy weather.

The systems board is located inside the display cabinet, behind the lower-left display module. To access the systems board:

1. Follow the safety requirements in Section 2.4, page 8.
2. Access the control panel (Section 4.5.1, page 23) and set the operating mode to OFF.
3. Open the display cabinet door (Section 6.2.1, page 40).
4. Remove the lower-left display module:
 - a. Locate the four retaining nuts that hold the module in place and remove the nuts using the supplied nut wrench or a 5/16-inch nut driver.
 - b. Carefully pull the display module away from and out of the cabinet. Electrical wiring that is attached to the back of the module can be damaged with too much force. Do not disconnect any wiring.
 - c. While holding the display module, locate the two hinged support arms indicated in Figure 6-3. Swing the arms outward and pull the extensions out all the way.

Figure 6-3. Accessing the systems board

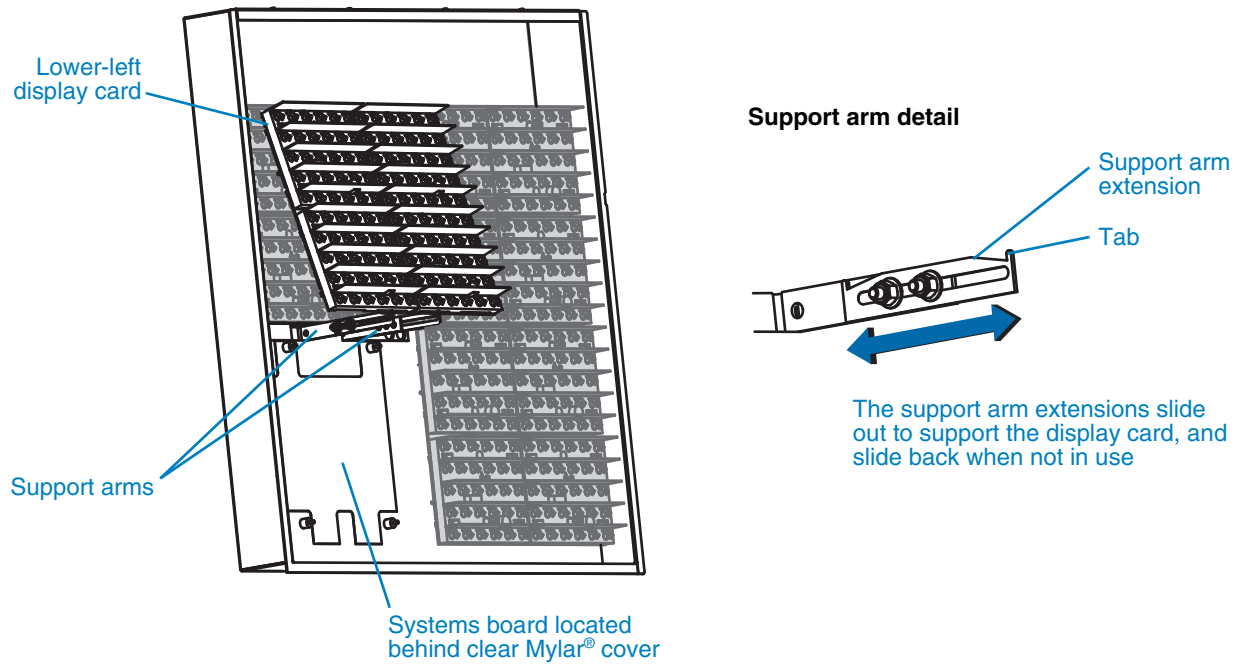

- d. Place the bottom of the lower-left display module so that the tabs on the support arm extensions fit into the slots on bottom of the module. Then lean the top edge of the module against the upper-left display module as illustrated in Figure 6-3.
- Ensure the support arms are spaced so that the display module is securely positioned and will not slide off or tip forward.
 - The systems board is located behind the clear Mylar® cover.

DIP switches

DIP switches on the systems board provide a variety of settings for the speed display:

KPH/MPH	Configures the units of measure for the speed limit display
A, B, and C	Configures the speed display's excessive speed message
D	Overrides the brightness control for photocells
DNLD/UPLD	Used for diagnostics and system software upgrades

- DIP switches on the systems board are called out in Figure 6-4.
- DIP switch settings are described in Table 6-1.

Figure 6-4. DIP switches on the systems board

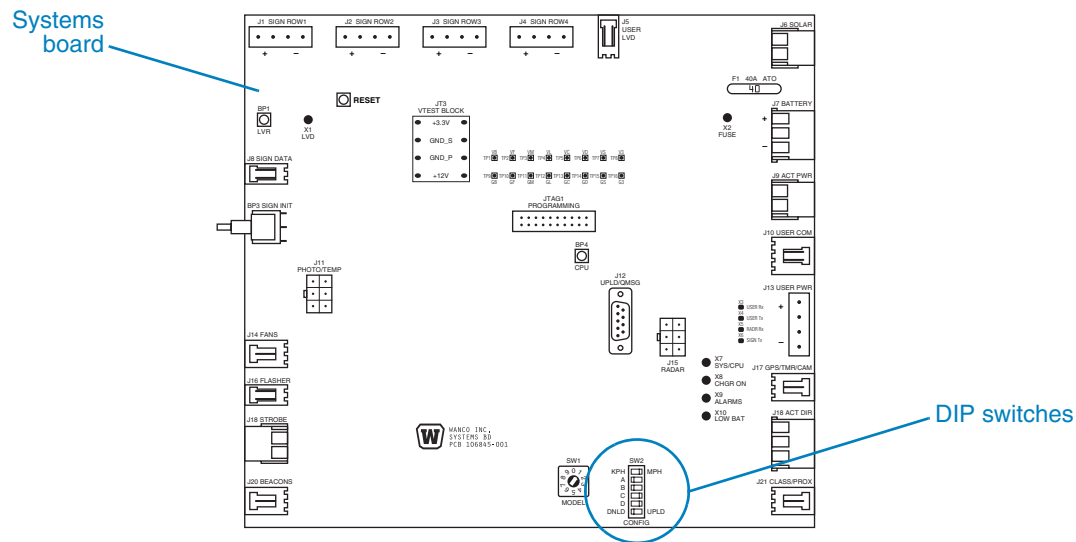

Table 6-1. DIP switch settings

	Switch	Setting	Description	
Units of measure	KPH/MPH	<input type="checkbox"/> <input type="checkbox"/>	km/h Vehicle speed is displayed in kilometers per hour (km/h)	
	KPH/MPH	<input type="checkbox"/> <input checked="" type="checkbox"/>	mph Vehicle speed is displayed in miles per hour (mph)	
Excessive speed message	A	<input type="checkbox"/> <input type="checkbox"/> <input type="checkbox"/>	blank When vehicle exceeds 130% of set speed limit, speed display is blank	
	B	<input type="checkbox"/> <input type="checkbox"/> <input checked="" type="checkbox"/>	SLOW DOWN When vehicle exceeds 130% of set speed limit, SLOW DOWN message is displayed	
	C	<input type="checkbox"/> <input type="checkbox"/> <input checked="" type="checkbox"/>	<input type="checkbox"/>	When vehicle exceeds 130% of set speed limit, frowning face symbol is displayed
	A	<input type="checkbox"/> <input type="checkbox"/> <input checked="" type="checkbox"/>	<input type="checkbox"/>	When vehicle exceeds 130% of set speed limit, alert symbol is displayed
	B	<input type="checkbox"/> <input type="checkbox"/> <input checked="" type="checkbox"/>	<input type="checkbox"/>	When vehicle exceeds 130% of set speed limit, diamond symbol is displayed
	C	<input type="checkbox"/> <input type="checkbox"/> <input checked="" type="checkbox"/>	<input type="checkbox"/>	When vehicle exceeds 130% of set speed limit, bar symbol is displayed
	A	<input type="checkbox"/> <input type="checkbox"/> <input checked="" type="checkbox"/>	<input type="checkbox"/>	When vehicle exceeds 130% of set speed limit, four corners symbol is displayed
	B	<input type="checkbox"/> <input type="checkbox"/> <input checked="" type="checkbox"/>	alternating and <input type="checkbox"/>	When vehicle exceeds 130% of set speed limit, alternating double diamond symbols are displayed
Display brightness	D	<input type="checkbox"/> <input type="checkbox"/> <input type="checkbox"/>	100% Speed display brightness is set to 100% in DEMO mode	
	D	<input type="checkbox"/> <input type="checkbox"/> <input checked="" type="checkbox"/>	photocell Brightness of speed display is controlled by photocells in all operating modes	
Serial communications	DNLD/UPLD	<input type="checkbox"/> <input type="checkbox"/>	download Serial port on control panel can be used for downloading system data for diagnostics	
	DNLD/UPLD	<input type="checkbox"/> <input checked="" type="checkbox"/>	upload Serial port on control panel can be used for uploading software upgrades to the system	

Replacing the systems board

If the systems board malfunctions or is damaged, it may be necessary to replace it.



CAUTION

Wind can cause the display cabinet door or display module to fall, resulting in equipment damage and injury.

Do not attempt to access the systems board in windy weather.

To replace the systems board:

1. Follow the safety requirements in Section 2.4, page 8.
2. Access the control panel (Section 4.5.1, page 23) and set the operating mode to OFF.
3. Access the battery box and remove the inline fuse (see Figure 6-8, page 59).
4. Open the display cabinet door (Section 6.2.1, page 40).
5. Remove the lower-left display module:
 - a. Use the instructions in Section 6.2.6, page 50, to remove the module. Mark each set of wires as you disconnect them, so you will know where to reconnect them when reinstalling the module.
 - b. Set the module aside on a clean, flat surface.
6. Remove the systems board:
 - a. The systems board is located behind the clear Mylar cover. To access the systems board, lift the cover out of the way.
 - b. One at a time, remove each wiring connection from the systems board. Mark each set of wires as you remove them, so you will know where to reconnect them when installing the replacement systems board.
 - c. When all the wiring has been disconnected, locate and remove the four nuts that hold the systems board in place.
 - d. Remove the systems board from the display cabinet and place it into a pink or red anti-static bag for shipment back to the factory.
7. Install the replacement systems board:
 - a. Prepare the replacement systems board by setting switches to the desired positions, matching the settings on the old systems board or using the information in "DIP switches" on page 44.
 - b. Locate rotary switch SW1 (Model), to the left of the DIP switches, and set it to position 1.

- c. Place the replacement systems board into position in the display cabinet and install it using the four nuts you removed in Step 6.
 - d. One at a time, make each wiring connection to the systems board using the wiring you marked in Step 6. Use care to make each connection at the proper location. (For a diagram of the systems board with all wiring connections called out, see Figure 6-9, page 61.)
8. Reconnect wiring to the lower-left display module:
 - a. While holding the module upside-down with its back facing you (in this position, the arrow on back of the module points down), reattach the data input and output wires, then the power connector.
 - b. Carefully rotate the module so that it is right-side up with the back of the module facing the cabinet (in this position, the arrow on back of the module points up, indicating the top of the module). Use care to avoid tangling or pulling on the wires.
9. Referring to Figure 6-3, page 44, place the module on the support arms:
 - a. Locate the two hinged support arms. Swing the arms outward and pull the extensions out all the way.
 - b. Place the bottom of the display module on the support arms so that the tabs on the arm extensions fit into the slots on bottom of the module. Then lean the top edge of the module against the upper-left display module.
 - c. Ensure the support arms are spaced so that the display module is securely positioned and will not slide off or tip forward.
10. Access the battery box and reinstall the inline fuse (see Figure 6-8, page 59).
11. Looking at the systems board, verify the green LED marked "X7 SYS/CPU" is blinking.
12. At the control panel, set the operating mode to STATUS.
13. Verify all four modules on the speed display are showing the system status variables correctly. Verify all variables that are shown.
14. Restore the display cabinet and sign to operating condition:
 - a. At the control box, set the operating mode to OFF.
 - b. Lift the display module off the support arms, slide the arm extensions all the way inward, and swing the arms back into their stored positions.
 - c. Position the lower-left display module in its proper place, in front of the systems board, using care not to pinch the wiring behind the module.
 - d. Using the supplied nut wrench or a 5/16-inch nut driver, install and tighten the four nuts that hold the module in place.
15. Test the radar to ensure it is functioning correctly (see Section 5.4, page 36).
16. Close and latch the display cabinet door (see Section 6.2.1, page 40).

6.2.5 Selector board

The selector board (Figure 6-5) includes switches, which allow for configuration of the speed sign behavior, and wiring connections. It is located inside the control box, behind the control panel.

There are no serviceable components on the selector board; if it fails, it must be replaced. To replace the selector board:

1. Follow the safety requirements in Section 2.4, page 8.
2. Access the control panel (Section 4.5.1, page 23) and set the operating mode to OFF.
3. Access the battery box and remove the inline fuse (see Figure 6-8, page 59).
4. Disconnect the control panel wiring:
 - a. Four screws hold the panel in place. Use a Phillips-head screwdriver to remove all four screws.
 - b. To expose the wiring connections on back of the selector board, gently rotate the top of the panel downward. Electrical wiring that is attached to the back of the board can be damaged with too much force. Do not turn the board left or right.
 - c. Referring to Figure 6-5, and being careful to avoid using too much force, unplug the system power connector by pulling it straight out, away from the board. Then unplug the low-voltage LED wires by pushing down on the locking tab and pulling the plug sideways, away from the connector. Repeat for the system communications wires, pulling that plug toward you, away from the connector.
5. Carefully remove the control panel from the control box and place it face up on a clean, dry surface.
6. Detach the selector board from the control panel:
 - a. Using a small slotted screwdriver, remove the two knobs from the rotary switches by loosening the set screw on each knob, located on the wide end of the knob (opposite of the pointer end) and pulling the knobs off the switches.
 - b. Using a wrench or pliers, loosen and then remove the two hex nuts that hold the rotary switches and the selector board to the control panel.
 - c. Lift the control panel away from the selector board.
7. Place the old selector board in a pink or red anti-static bag for shipment back to the factory.
8. Install the new selector board on the control panel:
 - a. Fit the rotary switches on the new board into the holes in the control panel.
 - b. Attach the board to the panel by threading the two hex nuts onto the switches. Tighten each nut with a wrench or pliers, just past hand-tight.
 - c. Insert the two knobs onto the rotary switches and tighten their set screws.

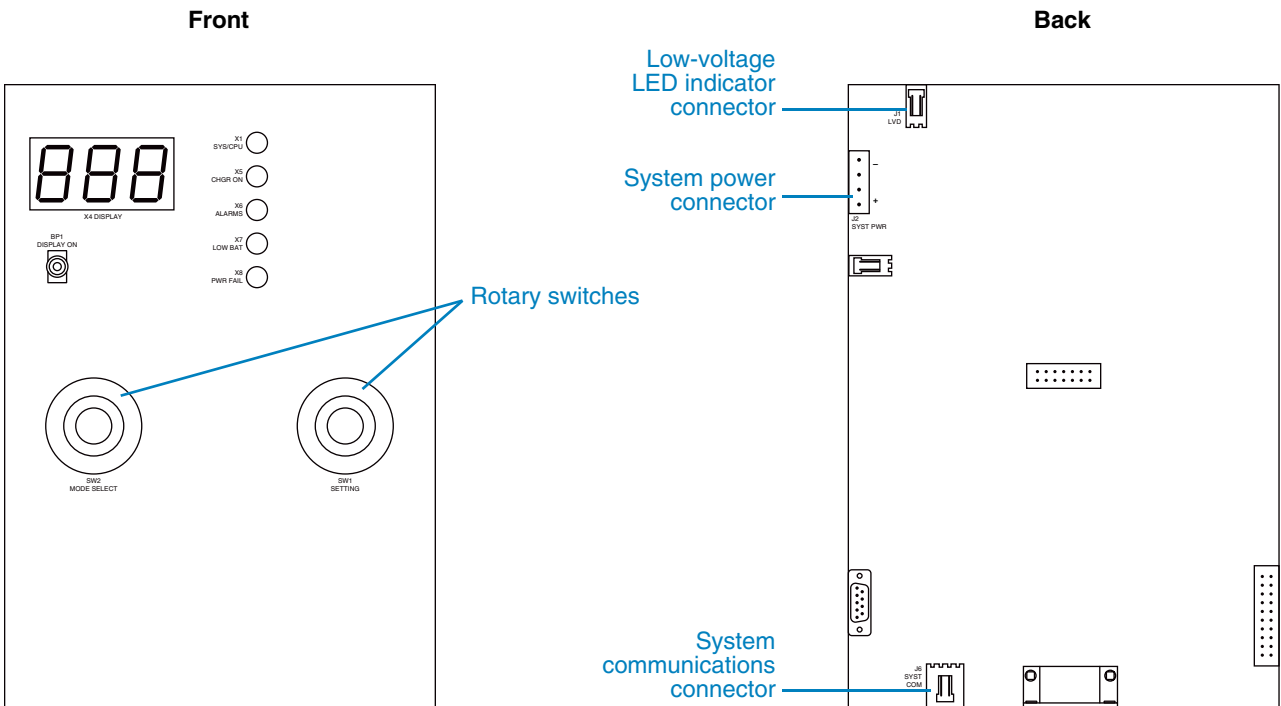
Figure 6-5. Selector board

9. Install the control panel assembly in the control box:
 - a. With the control panel face down, rest its bottom edge in the control box.
 - b. Taking care not to drop the control panel, make wiring connections to the back of the selector board.
 - c. Carefully tilt the control panel up, into its proper upright position.
 - d. Align the holes in the panel to the threaded holes in the back of the control box, then reinstall the four screws you removed in Step 4.
10. Access the battery box and reinstall the inline fuse (see Figure 6-8, page 59).
11. At the control panel, set the operating mode to STATUS, and ensure all functions are working properly.
12. Close and lock the control box.

6.2.6 Display modules

The speed display's LED display modules can be replaced when damaged or if LEDs fail to light.

Initialization

After installing a display module, the module must be initialized so that it will display the proper LED sequence. Each module has an address embedded in its program chip; initialization sets the address, and is therefore required each time a module is placed in a new position or replaced in the cabinet.

Wiring problems

If no LEDs on a display module will light (i.e., the module appears not to be working), the cause could be faulty wiring or a wiring connection. To troubleshoot for a wiring problem:

1. Use the instructions below to access the module and check its wiring connections before removing the module. If the wiring connections are good, proceed to Step 2.
2. Use the instructions below to remove two modules, switch their positions, and reconnect them.
 - If the suspect module is not working in its new position, the problem is with the module, not the wiring.
 - If the second module (the module you switched with the suspect module) is not working, then the problem is with the wiring.

Replacing a display module

Before replacing a display module, check for wiring problems as described above.



CAUTION

Wind can cause the display cabinet door or display module to fall, resulting in equipment damage and injury.

Do not attempt to replace a display module in windy weather.

To replace a display module, follow these steps:

1. Follow the safety requirements in Section 2.4, page 8.
2. Access the control panel (Section 4.5.1, page 23) and set the operating mode to OFF.
3. Open the display cabinet door (Section 6.2.1, page 40).

4. Remove the desired display module:
 - a. Identify the display module to be replaced, and locate the four retaining nuts that hold the module in place.
 - b. Using the supplied nut wrench or a 5/16-inch nut driver, remove the four nuts.
 - c. Carefully pull the display module away from and out of the cabinet. Electrical wiring that is attached to the back of the module can be damaged with too much force.
 - d. To expose the wiring connections on back of the module, gently rotate the bottom of the module upward (see Figure 6-6). Do not turn the board left or right.
 - e. Being careful to avoid using too much force, first unplug the power connector by pulling it straight out, away from the display module. Then unplug the data input wires by pushing the locking tab down and pulling the plug sideways, away from the connector. Repeat for the data output wires. The lower-right display module does not have an output wiring connection.
 - f. Set the old display module aside.
5. Install the replacement display module:
 - a. While holding the replacement module upside-down with its back facing you (in this position, the arrow on back of the module points down), attach the data input and output wires, then the power connector.
 - b. Carefully rotate the module so that it is right-side up with the back of the module facing the display cabinet (in this position, the arrow on back of the module points up, indicating the top of the module). Use care to avoid tangling or pulling on the wires.

Figure 6-6. Rotate display module

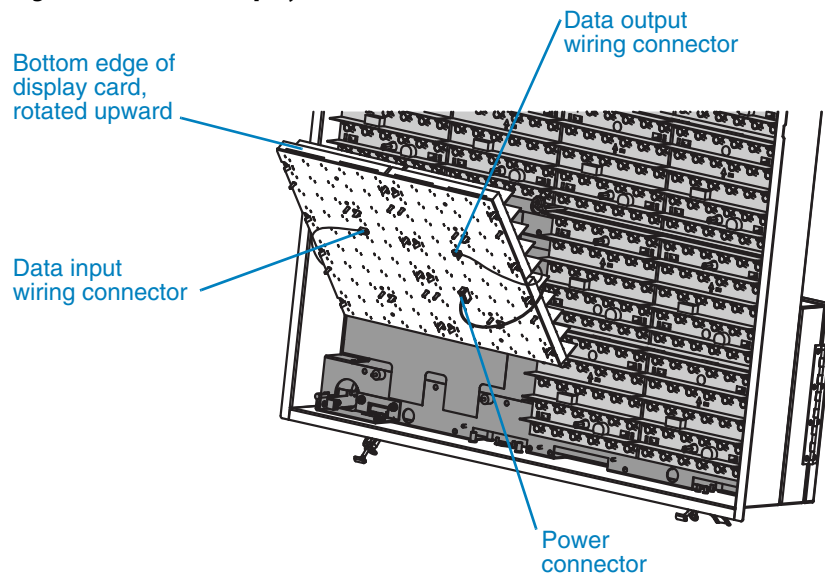

- c. If the module is in the lower-left position in the cabinet, skip to Step 6; otherwise, position the module in place in the cabinet, using care not to pinch the wiring behind the module.
 - d. Using the supplied nut wrench or a 5/16-inch nut driver, install and tighten the four nuts that hold the module in place.
 6. Position the lower-left display module for access to the systems board:
 - a. If the replacement module is in the lower-left position in the cabinet, locate the two hinged support arms indicated in Figure 6-3, page 44; otherwise, remove the lower-left display module as described above (but *do not* disconnect its wiring), then locate the support arms.
 - b. Swing the arms outward and pull the arm extensions out all the way.
 - c. Place the bottom of the lower-left display module so that the tabs on the arm extensions fit into the slots on bottom of the module. Then lean the top edge of the module against the upper-left display module as illustrated in Figure 6-3, page 44.
 - Ensure the support arms are spaced so that the display module is securely positioned and will not slide off or tip forward.
 - The systems board is located behind the Mylar cover.
 7. Use the systems board to initialize the replacement display module:
 - a. At the control panel, set the operating mode to SERVICE.
 - b. Locate the white initialize button (labeled "BP3 SIGN INIT") on the left side of the systems board (see Figure 6-7).
 - c. Press and hold the initialize button and observe the status LEDs on the systems board. After approximately 5 seconds, the LEDs will flash in sequence, indicating the display module initialization sequence is complete.
 - d. Release the button.
 8. Restore the display cabinet and sign to operating condition:
 - a. At the control box, set the operating mode to OFF.
 - b. Lift the lower-left display module off the support arms, slide the arm extensions all the way inward, and swing the arms back into their stored positions.
 - c. Position the lower-left display module in its proper place, in front of the systems board, using care not to pinch the wiring behind the module.
 - d. Using the supplied nut wrench or a 5/16-inch nut driver, install and tighten the four nuts that hold the module in place.
 - e. Close and latch the display cabinet door (see Section 6.2.1, page 40).

Figure 6-7. Initialize button and status LEDs on the systems board

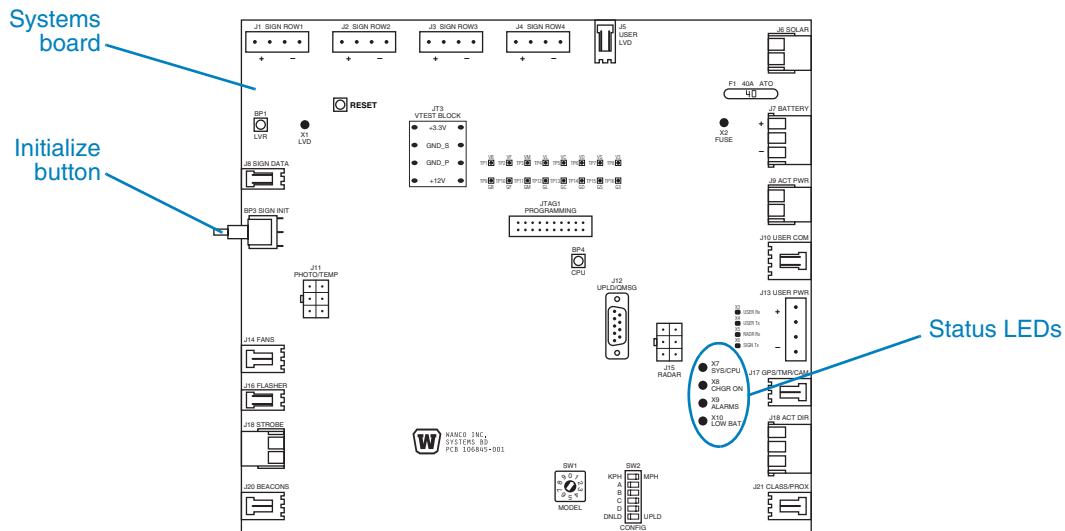

6.3 Power system

6.3.1 Solar panel

For the speed trailer’s solar charging system to function properly, the solar panel must be exposed to full sunlight during daylight hours.

The solar panel must be kept clean and unobstructed:

- When necessary, clean the solar panel with a soft cloth or sponge and a cleaning solution of mild detergent and warm water.
- If a shadow or any obstruction blocks even a portion of any of the solar panel, charging will be negatively affected and a significantly longer charge time will be necessary.

6.3.2 Batteries

Although the solar-charging system helps maintain battery health by keeping batteries fully charged when there is sun, and by shutting down power automatically before full discharge, regular maintenance is necessary for the batteries to function properly and for long battery life.

- When working on or around the batteries, always observe battery safety precautions (see below).
- Routinely inspect batteries and cables, clean surfaces and terminals, and check fluid levels and battery charge.

See the following pages for maintenance procedures.

Safety



DANGER

Explosive gases can cause blindness and severe injury.

When working on or near batteries:

- Wear eye protection
- Prevent sparks and open flames
- No smoking anywhere in the vicinity
- Keep children clear of the area



DANGER

Sulfuric acid can cause blindness and severe burns.

- Use caution when working on or near batteries
- Avoid contact with skin, face, and eyes
- Upon contact, seek medical help immediately
- Keep out of reach of children



WARNING

Fire hazard.

When working with the speed trailer batteries, never allow positive wiring to short to ground.

- Even when the battery is not in operation, self-discharge generates hydrogen gas that can explode. Always store and work on batteries in a well ventilated area.
- Always wear proper eye, face, and hand protection when working on or near batteries.
- Keep all sparks, flames, and cigarettes away from batteries at all times.
- When working with batteries, never allow positive wiring to short to ground.
- Never lean over batteries when testing or charging.
- Keep battery vent caps tight and level, except when watering batteries.
- To prevent short circuits and sparks, exercise caution when working with metallic tools or conductors near batteries.
- To reduce the risk of sparks, ensure connectors make good contact with battery terminals.
- Replace cables that you suspect might be worn or damaged. Replace cables that have visible fraying, cracks, or bare wires.
- If disconnecting speed trailer battery cables, always disconnect positive (+) cable first.*

**Removing the positive cable first is a requirement specifically for negative-ground systems.*

- At least once a month, coat cable connections with a protective spray, non-metallic grease, or petroleum jelly (such as Vaseline® brand) to prevent corrosion. Keep battery hold-downs painted.
- To lengthen battery life and prevent freezing, always keep batteries fully charged and keep cable connections clean and tight.
- Visually inspect batteries for physical damage, including cracks and leaking. Always replace damaged batteries immediately. Dispose of old batteries in accordance with local regulatory codes.
- Keep the battery box lid closed and latched unless you are performing maintenance or charging the batteries.

Charging

Battery voltage should be checked once a week, to ensure that the charging system is keeping the batteries charged. (For information about the charging system, see Section 5.5, page 37.) In northern locales during winter, when sunlight is less intense, battery voltage should be checked more often.

If the battery voltage is low because the charging system is not able to fully charge the batteries, use the external, AC-powered charger (located inside the battery box) when the batteries need charging.

After charging flooded (non-sealed) batteries, check battery fluid levels (see “Watering flooded batteries” on page 58).

Specific-gravity testing procedure

A specific-gravity test is the preferred testing method for flooded (non-sealed) batteries. For regular maintenance, perform specific-gravity testing on two or more cells on different batteries. Normal readings should be between 1.250 and 1.280. If readings are low, check all other cells and batteries to determine whether batteries are near the end of their operating life.

1. Observe battery safety precautions (see page 54).
2. Open vent cap and inspect fluid level.
3. Add distilled water until the plates are covered.
4. Fill and then drain a battery hydrometer. Repeat two to four times.
5. Using the hydrometer, pull out a sample. There should be enough sample fluid (electrolyte) to support the float.
6. Record the hydrometer reading.
7. Return the fluid to the battery cell.
8. Close and tighten the battery vent cap.
9. Repeat for the other cells of the battery.
10. Clean any spilled electrolyte.

11. Correct the hydrometer readings to 80°F (27°C) using ambient air temperature:
 - Add 0.004 for every 10°F above 80°F (5.6°C above 27°C).
 - Subtract 0.004 for every 10°F below 80°F (5.6°C below 27°C).
12. Refer to Table 6-2 to determine the battery charge requirements based on the corrected specific gravity.

Table 6-2. Battery charge requirements

Charge level,%	Specific gravity @80°F (27°C)	Open-circuit voltage, volts		Approx. required charge time, hrs.	
		6V batt.	12V batt.	5A	10A
100	1.277	6.37	12.73	0	0
95	1.268	6.34	12.68	3	1
90	1.258	6.31	12.62	5	2
85	1.248	6.28	12.56	8	4
80	1.238	6.25	12.50	10	5
75	1.227	6.22	12.44	13	6
70	1.217	6.19	12.37	16	8
65	1.206	6.16	12.31	18	9
60	1.195	6.12	12.24	21	10
55	1.184	6.09	12.17	23	12
50	1.172	6.05	12.10	26	13
45	1.277	6.37	12.03	28	14
40	1.268	6.34	11.96	31	16
35	1.137	5.95	11.89	34	17
30	1.124	5.91	11.81	36	18
25	1.111	5.87	11.74	39	19
20	1.098	5.83	11.66	41	21
15	1.087	5.79	11.59	44	22
10	1.079	5.75	11.51	47	23
5	1.037	—	—	—	—
0	1.000	—	—	—	—

Notes

1. Determine the battery charge level from the specific-gravity or voltage test readings. Specific-gravity testing is recommended over voltage testing, because it is possible for batteries to exhibit a valid voltage (surface charge) yet have no capacity to drive a load.
2. If charge level is above 70%, no charging is required. If charge level is below 10%, the battery may need replacing. Otherwise, determine the required charge time from the table. For charging with a Wanco battery charger, use the 5-amp column for a four-battery system, and the 10-amp column for a two-battery system.

Voltage testing procedure

Before performing a voltage test on flooded (non-sealed) batteries, consider a specific-gravity test (a more accurate indicator of battery charge) instead. For sealed batteries, the voltage test is the only testing method.

For accurate voltage readings, batteries must remain idle for 6 to 24 hours, which allows the voltage to equalize between the battery cells.

1. Observe battery safety precautions (see “Safety” on page 54).
2. Verify battery cables are disconnected and terminals are clean.
3. Using a voltmeter or multimeter, measure and record the DC voltage at each battery terminal.
4. If the voltage varies between batteries, recharge the batteries and perform the test again, or obtain appropriate test equipment from the battery manufacturer and follow the manufacturer’s instructions.
5. Refer to Table 6-2 to determine the battery charge requirements based on the measured voltage.

External AC charger

To charge the batteries with the external AC-powered charger, located inside the battery box:

1. Observe battery safety precautions on page 54.
2. Observe the following charging requirements:
 - Avoid charging batteries at temperatures above 120°F (49°C).
 - Never charge a frozen battery. Thaw batteries completely before charging.
 - Always charge batteries fully. Undercharging causes stratification and may result in the speed trailer shutting down unexpectedly.
3. Connect the charger to a standard 120-volt or 240-volt commercial power outlet.
 - If the charger appears not to be working, the fuse on the charger may be blown, or the power outlet may not be switched on.
 - The charger will not overcharge the batteries, even if left unattended for an extended period.
4. Charge the batteries until they reach 12.65 volts DC.
5. After charging is complete, disconnect the charger from the power outlet and stow the power cord inside the battery box.
6. Close and latch the battery box.

Watering flooded batteries

This section applies only to flooded (non-sealed) batteries. If your speed-trailer uses sealed batteries, you do not need to water the batteries.

CAUTION

Low battery acid can damage batteries.

Periodically check fluid level in each battery cell.

For proper and optimal functioning of the speed trailer, battery fluid levels must be maintained. Check fluid levels regularly and refill when necessary using the following guidelines:

- Observe battery safety precautions on page 54.
- Use only distilled or deionized water. Water with mineral content can cause the plates to corrode. Never add acid or additives to batteries.
- Open battery vent caps and inspect the fluid well for each cell. If necessary, add just enough distilled water to cover the plates. More water may be required after charging.
- Do not overfill batteries. Overfilling will result in overflowing of battery acid during use.
- Watering guns and automatic watering systems are acceptable for watering batteries. Do not use a common garden hose for watering.
- When finished, ensure all vent caps are tight and level.
- Charge batteries after refilling, then check again for proper fluid levels.
- When checking battery fluid levels, overfull batteries can be an indication of overcharging, operation at high temperature, or the battery nearing its end of life.

Cleaning

- Observe battery safety precautions on page 54.
- Keep batteries clean, avoiding accumulation of dust, dirt, and grime.
- To clean batteries, use a solution of 50% baking soda and 50% water. Do not allow cleaning solution or other material to enter battery cells. After cleaning, rinse batteries with clean water and allow to dry thoroughly.
- At least once a year, visually inspect terminals and cables for signs of corrosion, especially in hot temperatures.

Storage

- Observe battery safety precautions on page 54.
- Before storing the speed trailer or batteries:
 - Clean the batteries as described in “Cleaning” on page 58.
 - Check fluid levels as described in “Watering flooded batteries” on page 58.
 - To prevent freezing, ensure all batteries are fully charged.
- Store batteries in a cool, dry, well-ventilated location. The storage temperature should remain as low as possible without dropping below 32°F (0°C).
- Store batteries safely out of reach of children and pets.
- Check fluid levels and state of charge every week.
- If storing for more than a month without active solar charging, remove the in-line fuse in the battery compartment (see Figure 6-8).

Figure 6-8. In-line fuse

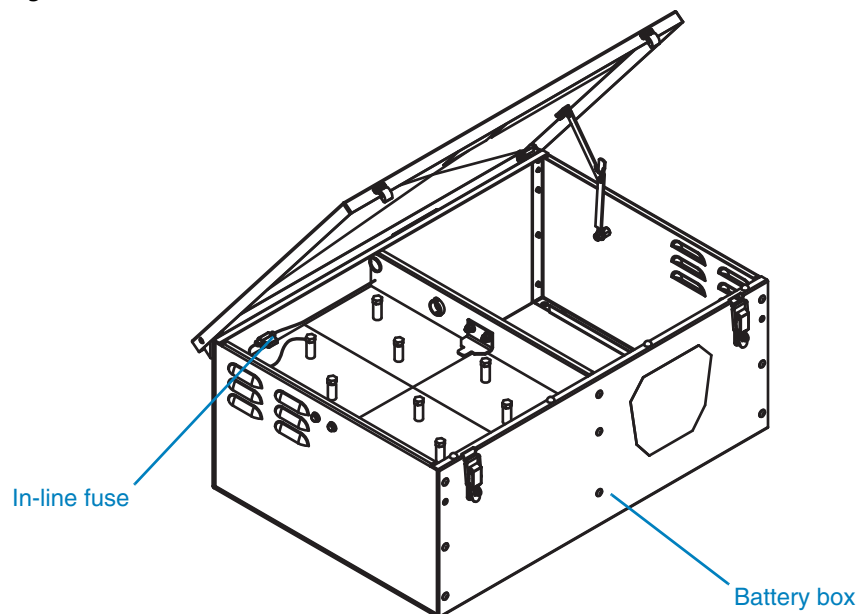

6.4 Wiring

The speed trailer has no exposed or user-serviceable wiring.

- Many wiring connections are made at the systems board, as illustrated in Figure 6-9. For additional information about the systems board, see Section 6.2.4, page 43.
- For a comprehensive wiring diagram, see Figure 6-10.

6.5 Replacement parts

For replacement parts, see the diagrams and parts lists starting on page 64, or contact the Wanco Service Department (see Section 1.4, “Where to obtain service,” page 3).

Figure 6-9. Systems board wiring connections

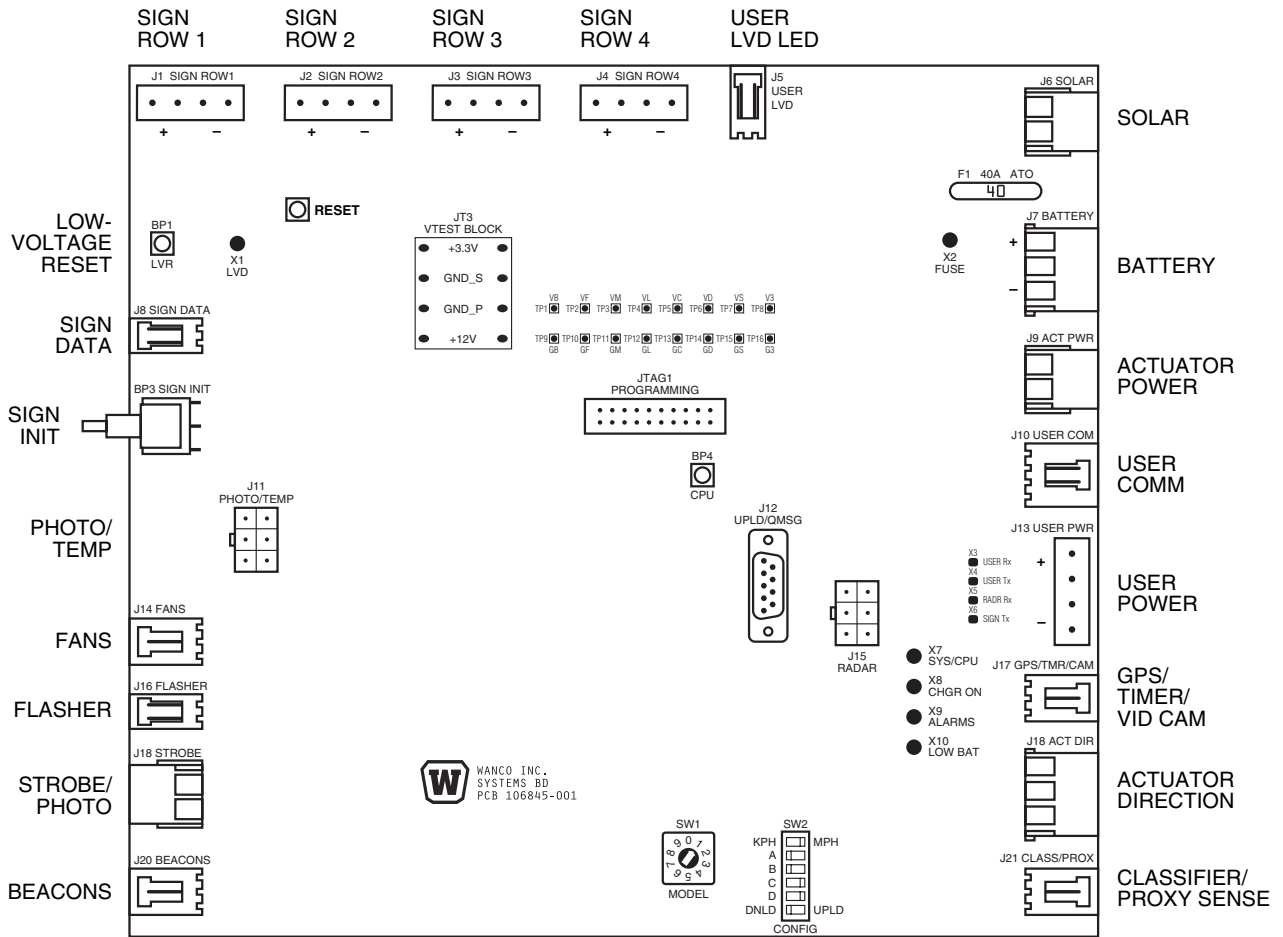
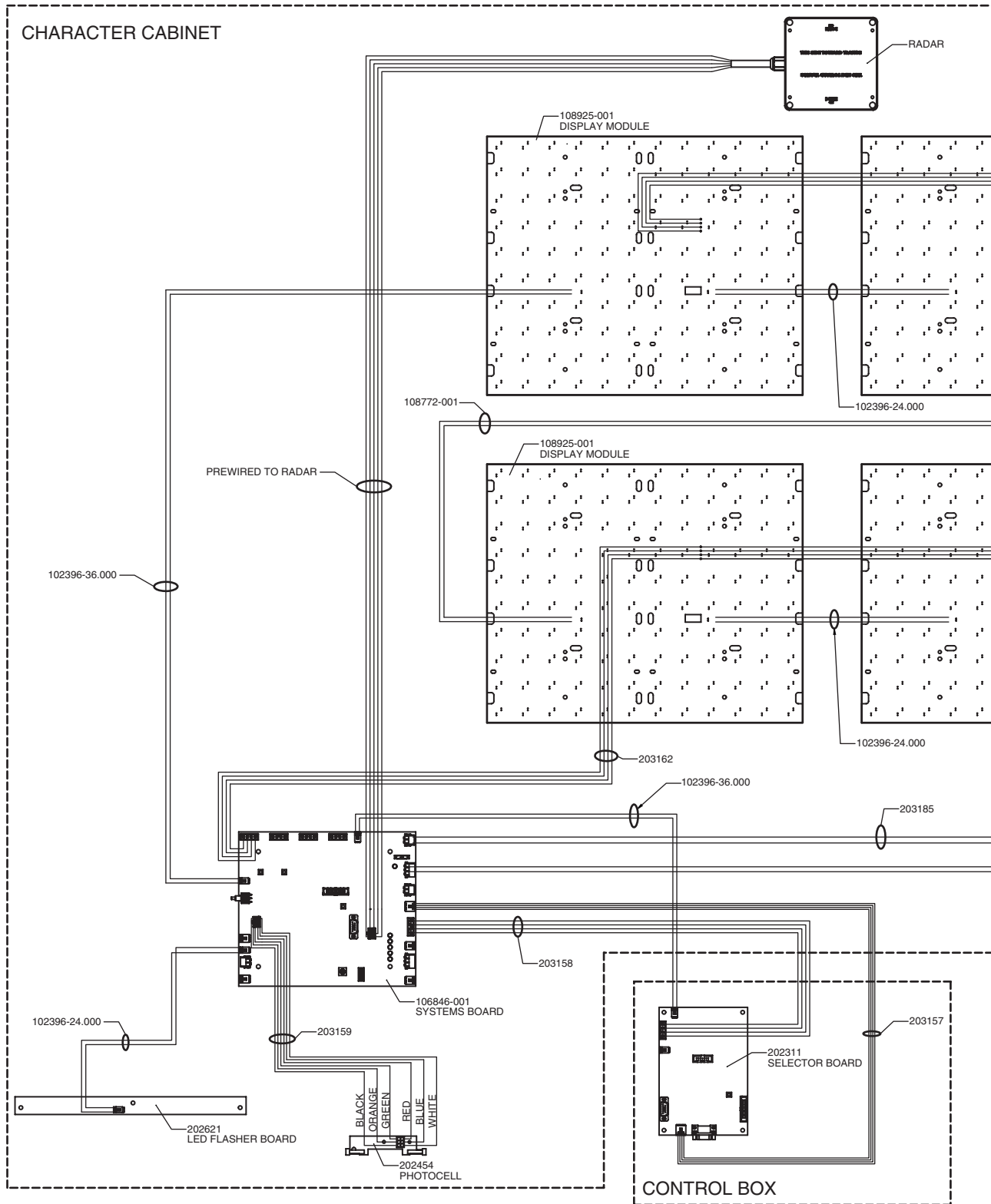

Figure 6-10. Wiring diagram



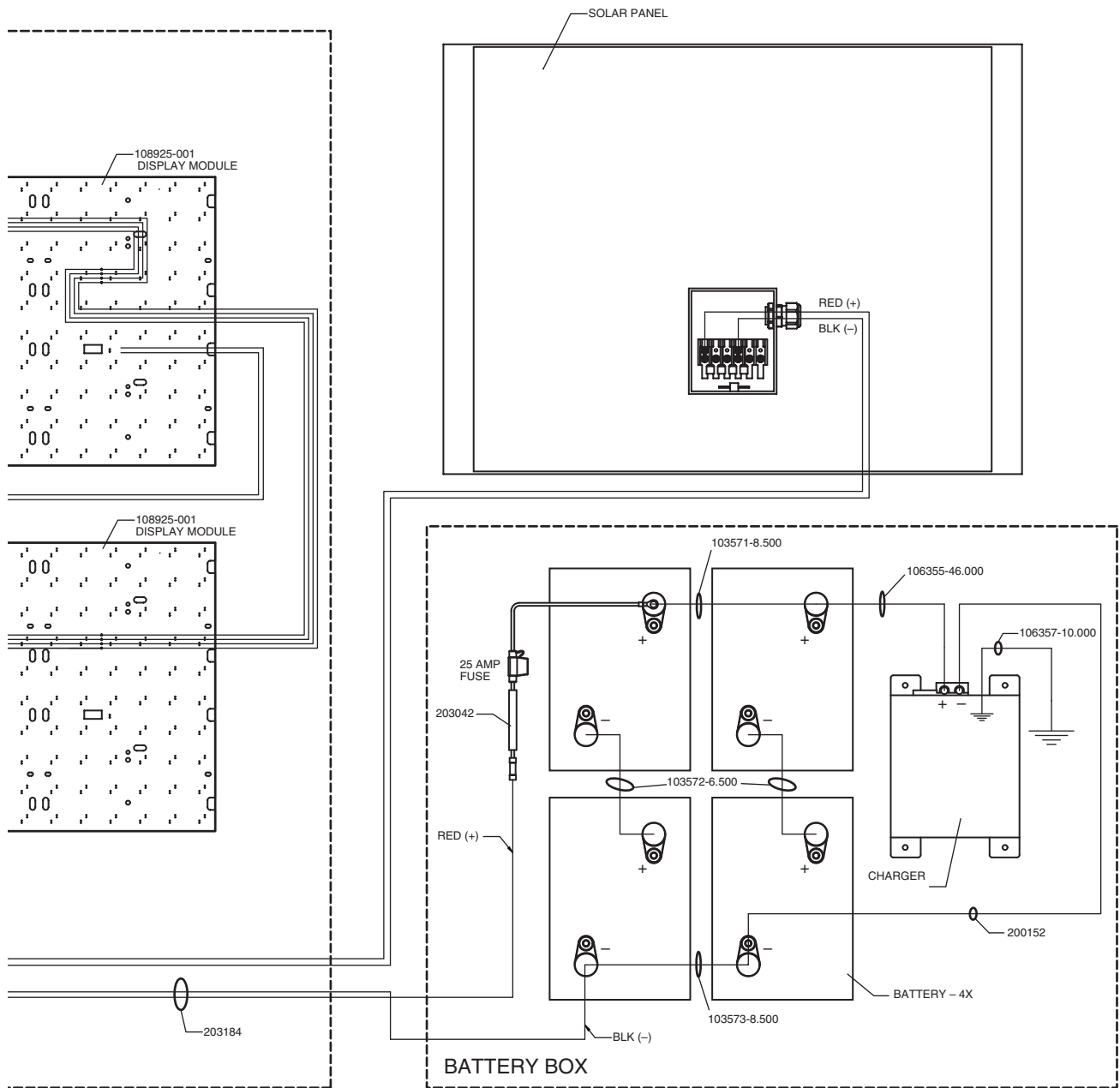

Table 6-3. Speed-display cabinet parts list

Item No.	Part No.	Description	Qty.
1	102033-001	Lid support, right side	1
2	102033-002	Lid support, left side	1
3	104417-001	Liquid-tight plug, 7/8" diameter	1
4	104828-001	Rubber bumper	1
5	106111-001	Photocell holder	1
6	106302-001	O-ring	1
7	106846-001	PCB, systems board	1
8	108427-001	Snap bushing	1
9	108743-001	Wanco tuning fork, 55 mph	1
10	204071	LED display module, 9"	4
11	202454	Photocell	1
12	202621	Red-blue flasher assembly	1
13	203027-P2	Interior bracket, top/bottom	2
14	203028-P2	Photocell bracket	1
15	203030	"YOUR SPEED" sign	1
16	203031	Display cabinet window	1
17	203032	Speed display door latch	2
18	203033	Display cabinet gasket	1
19	203034-P2	Window bumper bracket	1
20	203035-P3	Display cabinet door hinge	1
22	203039-P2	Interior center, top/bottom	1
23	203041-P2	Door frame	1
24	203043-P2	Radar bracket	1
25	202311	PCB, selector board	1
26	203096	Standoff, 8-32 × 1 1/2"	2
27	203047	Door gasket	1
28	203049-P3	Control box door	1
29	104221-001	Cam latch	2
—	104222-001	Key for cam latch (not shown)	2
30	203059	Control panel	1
31	203052-P3	Control box	1
32	203053	Control box rear gasket	1
33	203091	Control box grommet	1
34	203168	Wanco radar head	1
35	203341	Polyester cover for systems board	1
36	102314-001	Vibration mount for LED display module	16
37	203061	Vibration mount for systems board	4
38	104223-001	Cam latch seal	2
39	204194-P2	Swing arm extension	2
40	204195-P2	Swing arm	2
41	103810-001	Acorn nut, 1/4-20	5
42	104234-001	Standoff, 8-32 × 5/8"	4
43	104448-028	Button-head screw, #10-32 × 1/4"	8
44	100207-019	Hex screw, 1/4-20 × 5"	2
45	107557-001	Nut, #8-32	16

Figure 6-12. Trailer assembly, exploded view

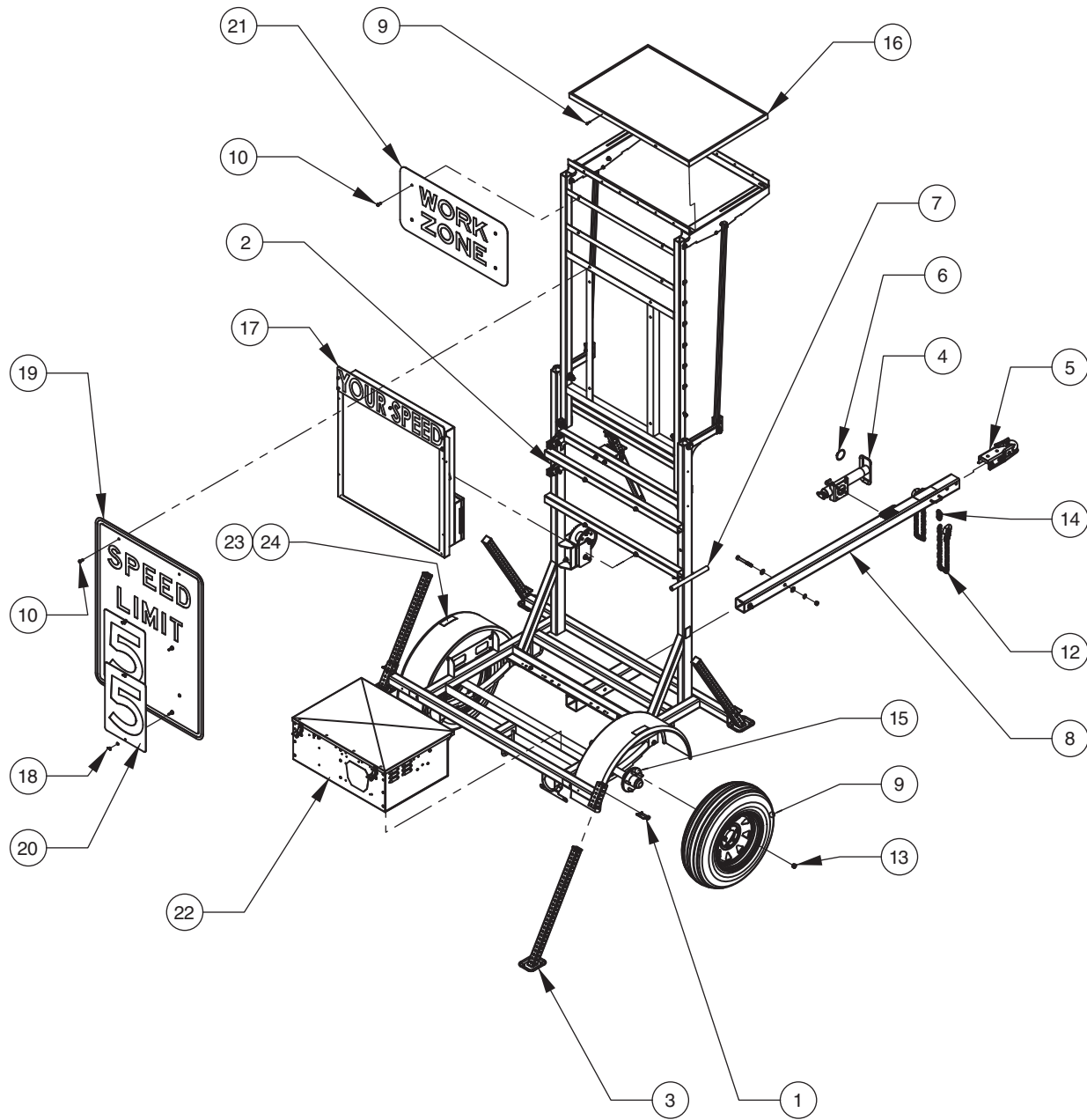

Table 6-4. Trailer assembly parts list

Item No.	Part No.	Description	Qty.
1	100080-001	Wire lock pin	4
2	100166-001	Single-groove pulley, 3"	2
3	100333-001	Stabilizer leg	4
4	100943-001	Top-wind swivel jack, 2000-lb. cap.	1
5	101677-002	Tow hitch, 2" ball	1
6	102919-003	Swivel jack snap ring, 2 1/2"	1
7	103223-001	Sight tube	1
8	103409-001P1	Drawbar	1
9	103505-003	Button-head screw, 1/4-20 x 1"	4
10	103666-003	Button-head screw, 3/8-16 x 1 3/4"	8
11	104591-003	Trailer tire with wheel, ST205/75D-15	2
12	104859-001	Tow chain with hook	2
13	200076	Hex nut, 1/2-13	10
14	201432	Quick-link for tow chain	2
15	201839	Axle assembly, 2000-lb. cap., 60" track	1
16	202485	Solar panel, 85-watt	1
17	203174	Display cabinet	1
18	203181	Wing-nut, 5/16-18	4
19	213676	Speed number set, 36" x 48"	1
20	213677	Speed limit sign, 36" x 48"	1
21	213678	Work zone sign, 36" x 18"	1
22	213690-C1	Battery box	1
23	101976-001	Caution decal, "NOT A STEP"	2
24	108420-200P	Fender, round bolt-on	2

Figure 6-13. Battery-box assembly, exploded view

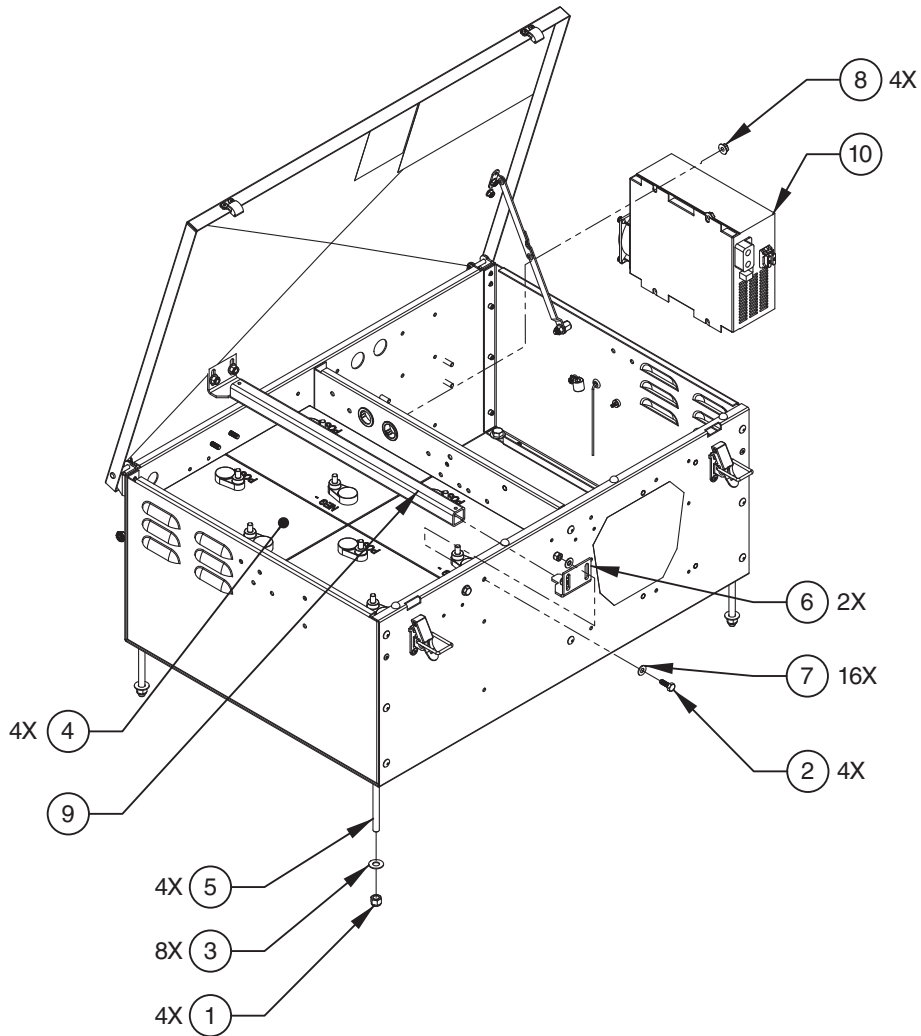

Table 6-5. Battery box parts list

Item No.	Part No.	Description	Qty.
1	100073-001	Hex nut, nylon insert lock 3/8-16	4
2	100207-002	Hex screw, 1/4-20 x 3/4"	4
3	100234-001	Flat washer, 3/8"	8
4	104131-001	Battery, 6V deep-cycle 215Ah	4
5	104177-005	Hex screw, 3/8-16 x 4"	4
6	104577-001P2	Battery hold-down bracket	2
7	105198-001	Flat washer, 1/4"	16
8	105280-001	Hex flange nut, 1/4-20	5
9	200912-P2	Battery hold-down tube	1
10	210268	Battery charger, 15A 60Hz 105/135VAC 12VDC	1



WANCO INC.

5870 Tennyson Street
Arvada, Colorado 80003

800-972-0755

303-427-5700

303-427-5725 fax

 www.wanco.com